

P38 Compact Series – Panel Mount Protocol Trackerball

DESCRIPTION

The P38 Compact Series are high specification, professional Trackerballs for use in demanding environments.

High-grade stainless steel shafts and bearings ensure a solid and precise pointer control while the patented floating seal technology limits ingress of aqueous solutions and particulates.

A choice of top plate and chassis configurations are available to provide various options on sealing, backlighting, bezel diameters and installation. The unit has been designed to be back of panel mounted as part of OEM keyboards and consoles.



FEATURES AND APPLICATIONS

- Optional sealing to IP65 (NEMA 6)
- Outputs: PS/2, USB (auto-select)
- Smooth operation in rugged environments
- Stainless steel shafts and bearings
- Various top plate configurations providing sealing and tracking force options
- Backlit ball options
- Custom connector options
- Optional anti-vandal kit
- For use in medical, kiosk and industrial applications
- OEM custom solutions available

SPECIFICATIONS

Mechanical

Weight	95 grams (phenolic/polyester ball) 275 grams (stainless steel ball)
Ball	Ø38.10 mm (1"), phenolic/polyester or AISI 440 stainless steel
Tracking force	10 grams nominal continuous – unsealed (IP40) 50-70 grams nominal continuous – sealed (IP65)
Housing material	ABS in black
Mounting position	Horizontal to 60° (IP65 sealed) Horizontal to 30° (non-sealed)
Sealing material	PTFE composite IP65 rated (qualified @ 25°C static)
Optional bezel material	AISI 316 stainless steel (optional)

Electrical

Protocol	PS/2, USB (auto-select)
Supply voltage	5V D.C. ± 5%
Supply current	15mA typical
Resolution	241 pulses per ball revolution (965 counts per ball revolution)
Output connector	8 Way JST, right-angled header, part no: S8B-PH-SM3-TB
Mating output connector	8 Way JST connector, part no: PH, CR or KR types
Switch Inputs	3 switches: left, middle, and right. connection through 4-way JST, right-angled header, part no: S4B-PH-SM3-TB.
Mating switch connector	4 Way JST connector, part no: PH, CR or KR types

Environmental

Operating temperature	0°C to +65°C
Storage temperature	-40°C to + 85 °C
Humidity	30% min, 95% max, non-condensing
Vibration	6-500Hz at 49m/s ² in all 3 axes
Shock	100g vertical axis, 40g horizontal axis
Lifetime	10 million ball revolutions (non sealed) >2 million ball revolutions – (sealed)
Impact	10 Joules (with anti-vandal Kit)
ESD	12kV air-discharge and 6kV contact discharge.

CONNECTION DETAILS

Connection is made to the P38 Trackerball by means of latching JST connectors (or equivalent). Tables 1 to 3 highlight the connection details. Custom connections are available (please contact your local sales office for further details).

Output connector:

Pin Number	USB, PS/2 (Auto select)
1	-
2	-
3	-
4	EARTH
5	+5V D.C.
6	PS/2 Data, D-
7	PS/2 Clock, D+
8	0V

Table 1 Output connections

Description: 8 way, 2mm pitch, right-angled connector
 Manufacturer: JST (or equivalent)
 Part No: S8B-PH-SM3-TB
 Mating connector: PH, CR or KR types

Switch input connector:

Pin Number	Function
1	Left switch
2	Middle switch
3	Right switch
4	0V

Table 2 Switch connections

Description: 4 way, 2mm pitch, right-angled connector
 Manufacturer: JST (or equivalent)
 Part No: S4B-PH-SM3-TB
 Mating connector: PH, CR or KR types

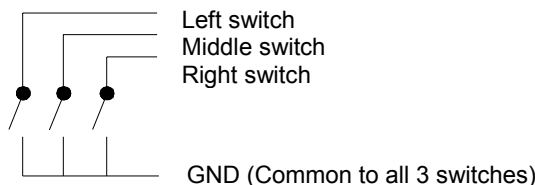
Switch schematic

Backlight connector (optional):

Pin Number	Function
1	+5V D.C.
2	0V

Table 3 Backlight connections

Description: 2 way, 2mm pitch, right-angled connector
 Manufacturer: Molex
 Part No: 22-05-7028
 Mating connector: Molex 22-01-1023

OPTIONAL CABLE ASSEMBLIES

Standard cable assemblies are available for connection to the Trackerball (see table 4). Alternative cable assemblies can also be supplied to customer specifications (please contact your local sales office for further details).

Cable Type	Cable Part No.	Description
USB Output cable	T9902204	Output cable, 2 metres, USB 'A' plug to 8 way JST
PS/2 Output cable	T9902217	Output cable, 2 metres, PS/2 Male to 8 way JST
Switch cable	T9902125	Switch cable, 4 way JST to bare wires, 500mm long
Backlight cable	T9902218	Backlight cable, 2 way Molex to bare wires, 500mm long
Adapter	A3900126	USB to PS/2 converter

Table 4 Cable assemblies

TRACKERBALL CONFIGURATION

The USB and PS/2 protocols provide features within the Trackerball software that can be selected using the DIP switch located on the printed circuit board. Table 5 details the assigned function of each switch.

USB/PS2 DIP switch functions

Switch	Function	OFF	ON
1	Orientation 1 Setting	See Figure.1	See Figure.1
2	Orientation 2 Setting	See Figure.1	See Figure.1
3	VX3 - Virtual 3 Axis Function	Feature Enabled	Feature Disabled
4	Smart Button – Button Lock	Feature Available	Feature Not Available

Factory default setting: DIP switches 1 and 2 OFF. All other DIP switches ON

Table. 5 DIP switch functions

Orientation

The orientation function allows the user to mount the P38 device in one of four positions (see fig.1 below). The orientation of the device is determined by the direction in which the output connector is facing (when viewed from the top of Trackerball device).

The Trackerball orientation can be selected to accommodate customer requirements for connector location and wiring.

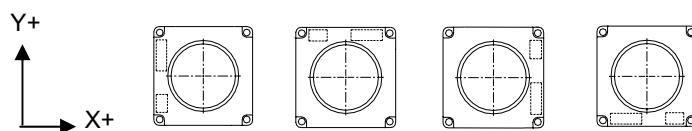

(Direction of output con. viewed from top of device)

Switch 1 (Orientation 1)	ON	ON	OFF	OFF
Switch 2 (Orientation 2)	ON	OFF	ON	OFF

Figure.1 Orientation settings

Smart switch

A patent protected button latch facility.

Operation:

- Press right button for 3 seconds or more to enable;
- Once enabled, pressing any button for approximately 1 second latches that button on;
- Press any button momentarily to de-latch;
- Disabled with a further press of the right button for 3 seconds or more;

VX3

VX3 is patent protected facility that provides the same 2 modes of functionality as a scroll wheel on a 3-axis mouse.

Operation:

- Press middle button once to latch scroll mode one (e.g. dynamic pan feature);
- Press middle button again to latch scroll mode two (e.g. 3rd axis zoom feature);
- Further middle button presses toggles between scroll mode one and scroll mode two;
- Press either left or right buttons to cancel feature and resume normal X-Y operation

DIMENSION DRAWING

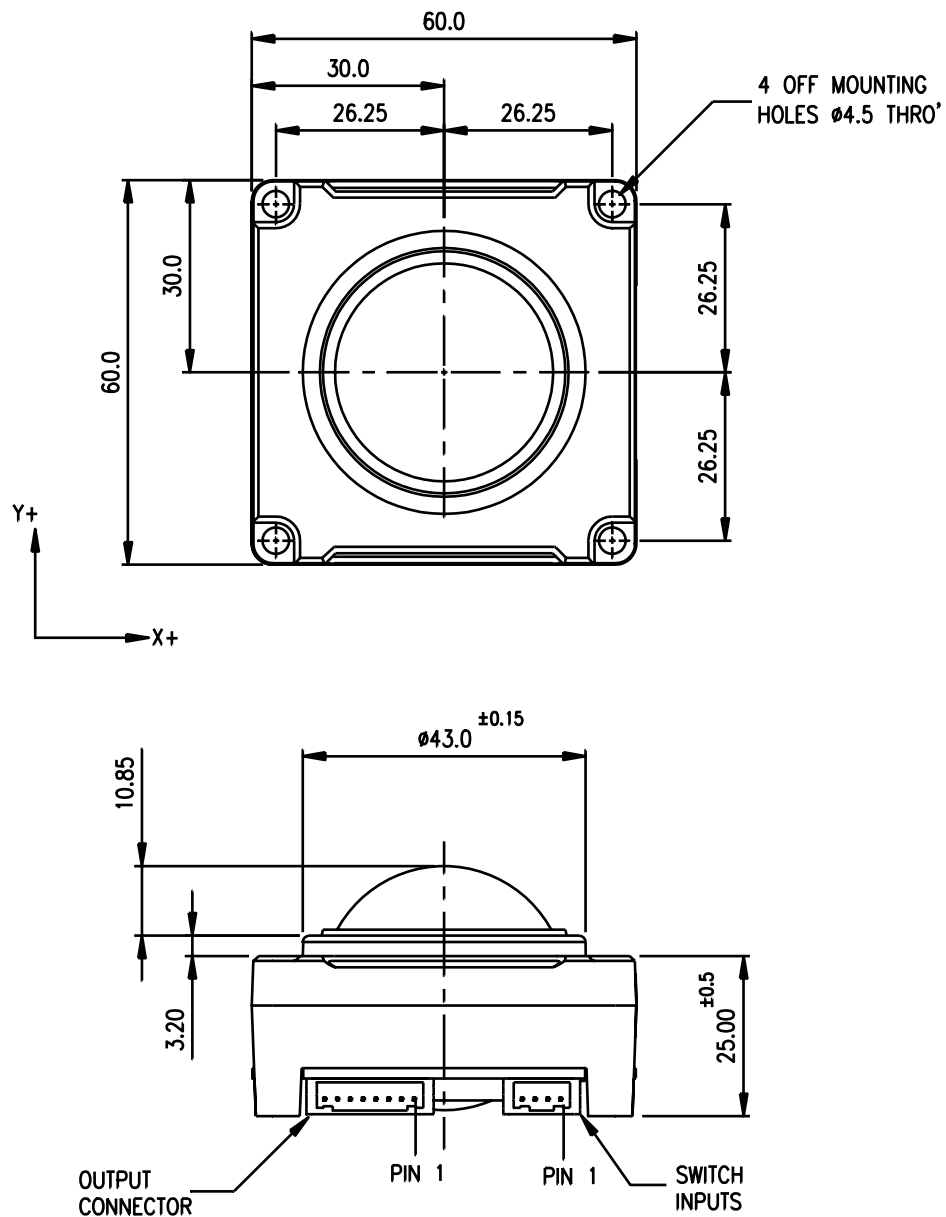

Dimensional drawing specifies factory default orientation.

All dimensions are in mm unless otherwise stated.

Tolerances +/- 0.2mm unless otherwise stated

Please note that an IGES model is available on request. Please contact your local sales office for more information.

OPTIONAL ANTI-VANDAL KIT

This optional back plate enables the unit to absorb a very high level of abuse/impact. When mounted correctly by the end-user, the back plate will limit any hostile impacts subjected to the device during operation in public access points. The back plate provides protection for shafts, bearings and other components within the unit and ensures continual functionality under demanding conditions. Typical applications include public information kiosks and consoles. The kit includes all necessary fasteners (see datasheet DS38301 for mounting details).

(Please contact sales for further details/specifications).

Product ordering code **P38-XXXXXX**. Please construct your standard product ordering code by selecting the numbers and letters to suit your specification:

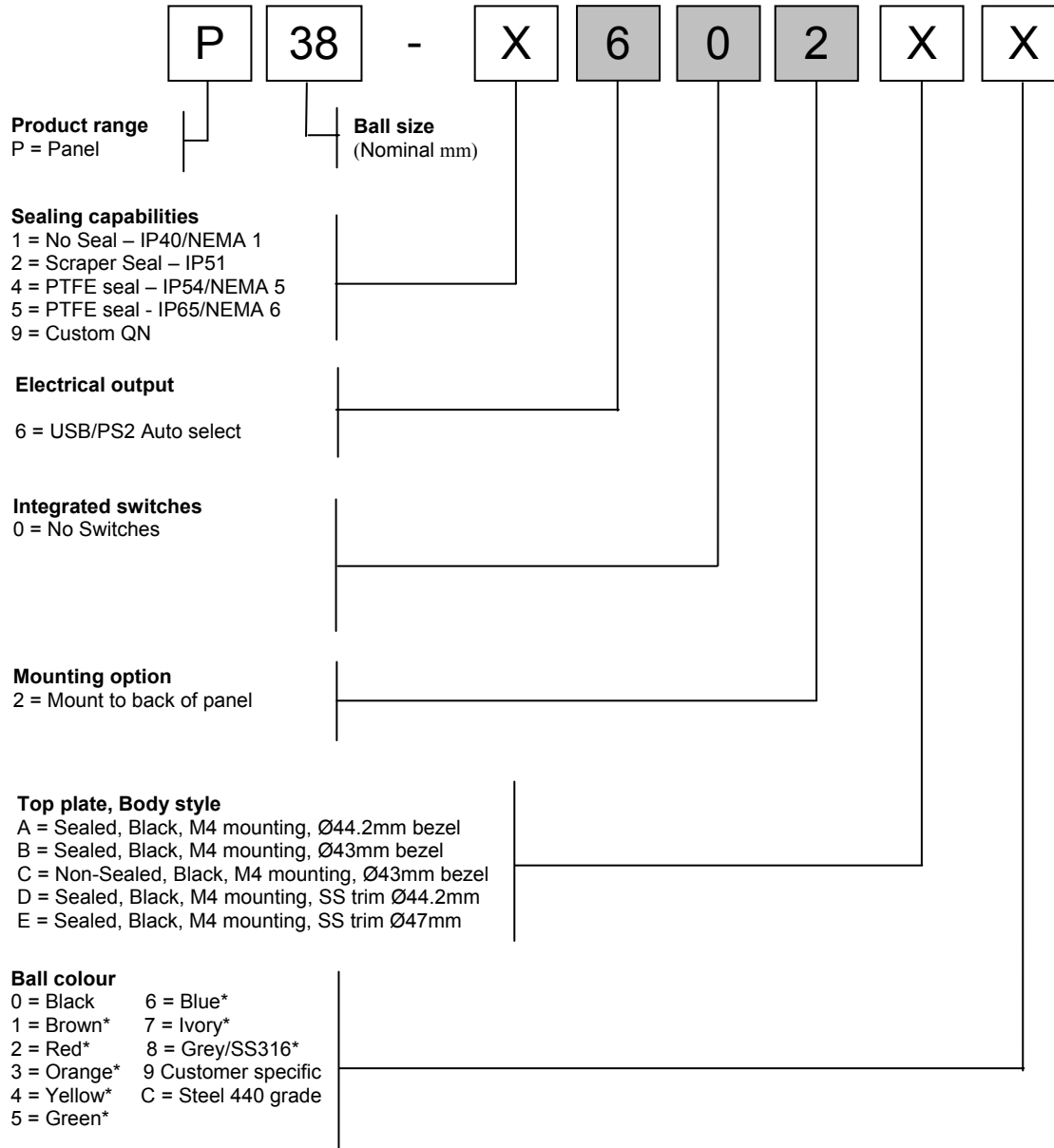

*Non standard colour – MOQ and lead-time may apply

Ordering Example:

P38-5602B0: Panel 38mm, sealed IP65, USB/PS/2 output, no switches, mount to back of panel, sealed (black), black ball.

OPTIONAL EXTRAS

- Anti-vandal option (See datasheet DS38301)
- Stainless steel trim
- Backlit ball (Various Colours)
- Optional external switches (See datasheet DS38201)
- Optional ball Colours (MOQ applies)
- Customer specific colour matching (MOQ applies)
- Cable assemblies (See datasheet DS38201)

Contact your local distributor for further details on product variants and custom specifications.