

X13 Series – 13mm Laser Trackball, Panel Mount, Quadrature Output



1. DESCRIPTION

Utilizing the latest and most advanced laser tracking technology, the X13 series laser Trackerball™ is an extremely high specification, contact-less device, ideal for the most demanding of cursor control applications.

The laser tracking engine provides accurate cursor motion at all speeds, combining the benefits of solid state sensing (no moving parts except the ball) with the aesthetics, functionality and performance associated with the Cursor Controls product range.

The design incorporates a removable top ring as standard to allow for easy cleaning, decontamination, sterilisation and maintenance - ensuring continued optimum performance and operation under the harshest of conditions.

The X13 series trackballs are available with a variety of electrical outputs, tracking force options, and sealing capabilities up to IP68.

The trackball has been designed to be back of panel mounted as part of OEM keyboards and consoles

2. FEATURES

- Solid state sensing technology – laser tracking engine
- Sealing up to IP68
- Output: TTL Quadrature
- Smooth operation in rugged environments
- Various top plate configurations
- Custom connector options

3. APPLICATIONS

- Medical systems
- Marine systems
- Custom keyboard applications
- Industrial consoles
- OEM custom solutions available

7. DIMENSION DRAWING

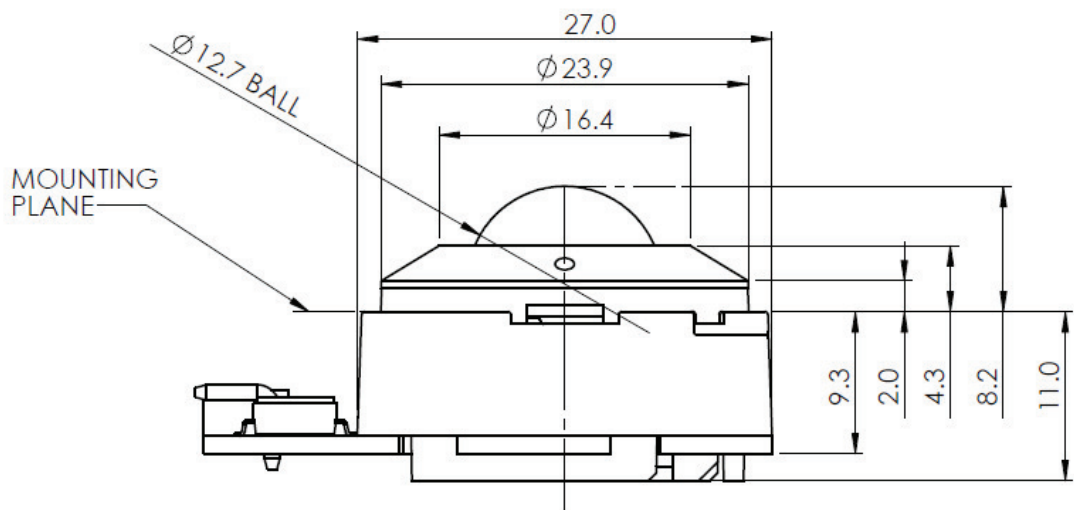
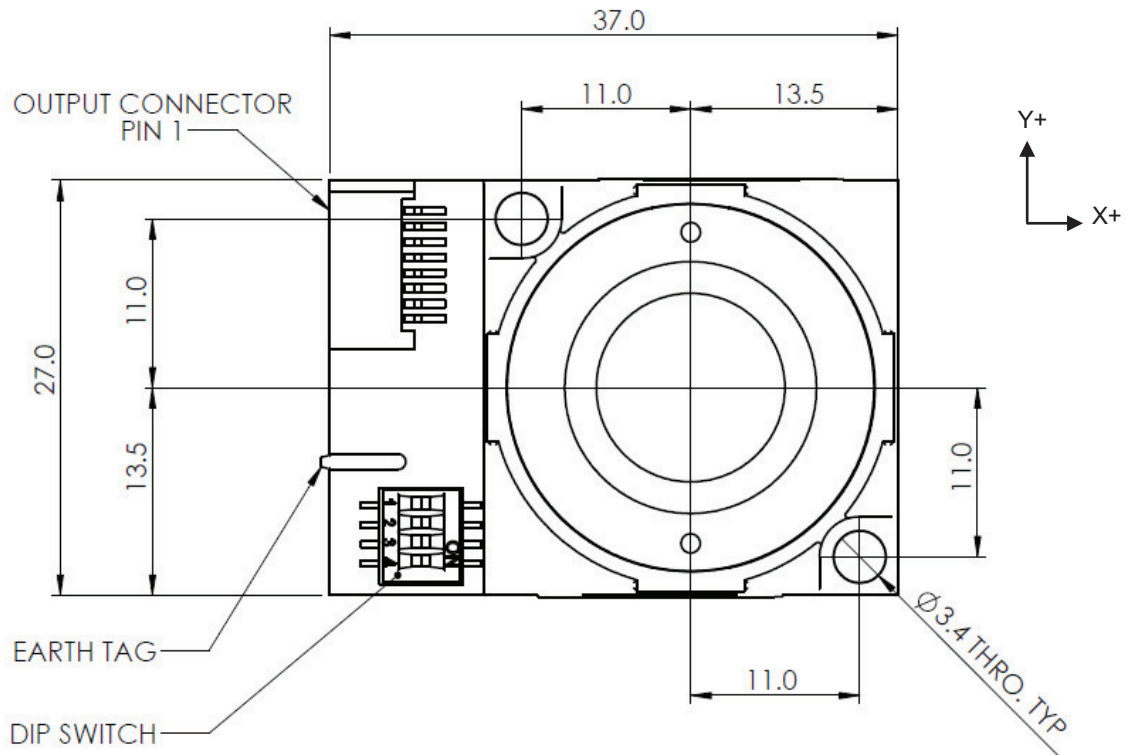

Dimensional drawing specifies factory default orientation.

All dimensions are in mm unless otherwise stated.

Tolerances +/- 0.2mm unless otherwise stated

Please note that an IGES model is available on request. Please contact your local sales office for more information.

8. PRODUCT ORDERING CODE SYSTEM

Please construct your standard product ordering code by selecting the numbers and letters to suit your specification:

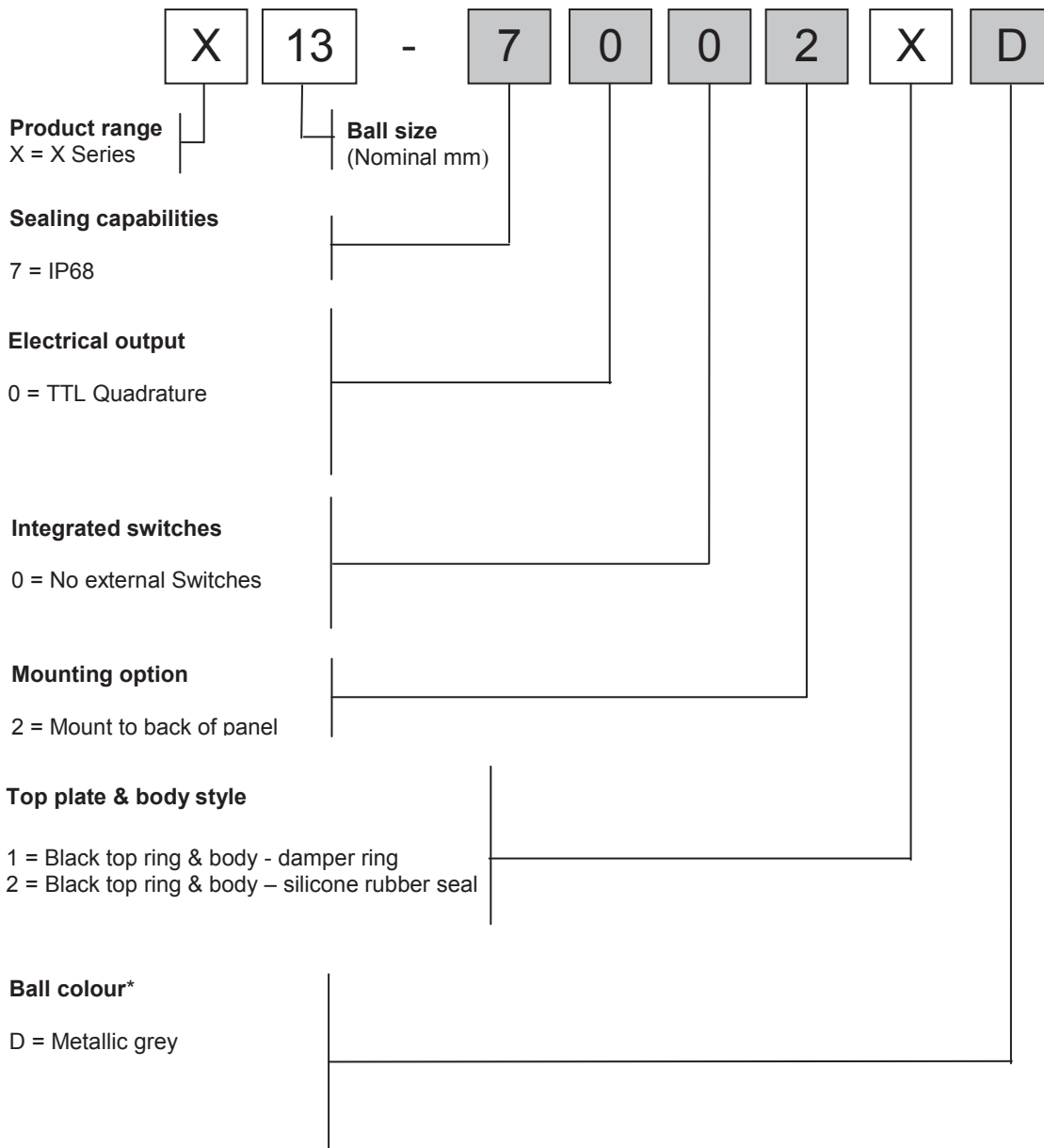

*For further options on ball colours please contact your local sales representative

8.1 Ordering Example

X13-70021D: X13, IP68, TTL Quadrature, no switches, mount to back of panel, black top ring - damper ring, metallic grey ball.