

P25 Compact Series – Ø25mm Panel Mount Trackball, Sealed/Non-sealed, Quadrature output



1. DESCRIPTION

The P25 Compact Series are rugged professional trackballs ideal for use in the most demanding of applications where space is at a premium. The compact series incorporates the same proven technology found in the well-established P38 trackball range, providing the user with the same high specification trackballs in a smaller package. High-grade stainless steel shafts and bearings ensure a solid and precise pointer control while the patented floating seal technology limits ingress of aqueous solutions and particulates. The P25 Compact Series trackballs have been designed to be back of panel mounted as part of OEM keyboards and consoles

2. FEATURES

- Sealing options up to IP65 (BS EN 60529)
- Outputs: TTL Quadrature
- Steel core ball for precise control
- Smooth operation in rugged environments
- Stainless steel shaft and bearings
- Various top plate configurations providing sealing and tracking force options
- Custom connector options
- Optional anti-vandal kit

3. APPLICATIONS

- Control systems
- Medical systems
- Navigation systems
- Compact keyboards
- Industrial consoles
- Laptops & palmtops
- OEM custom solutions available

6. OUTLINE DRAWING

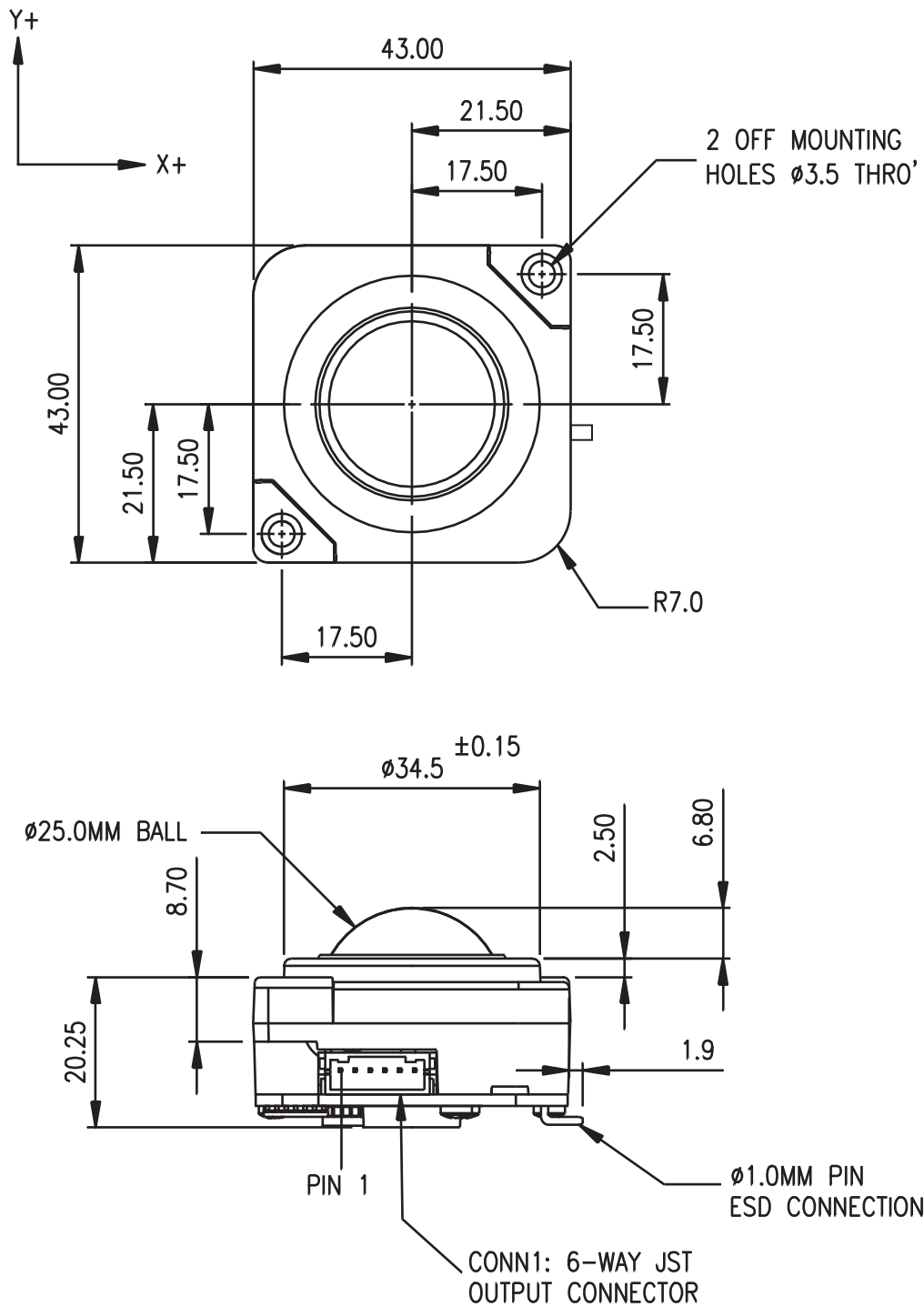

Dimensional drawing specifies factory default orientation.
 All dimensions are in mm unless otherwise stated.
 Tolerances +/- 0.2mm unless otherwise stated
 Please note that an IGES model is available on request. Please contact your local sales office for more information.

7. PRODUCT ORDERING CODE SYSTEM

Please construct your standard P25 Compact Series product ordering code by selecting the numbers and letters to suit your specification:

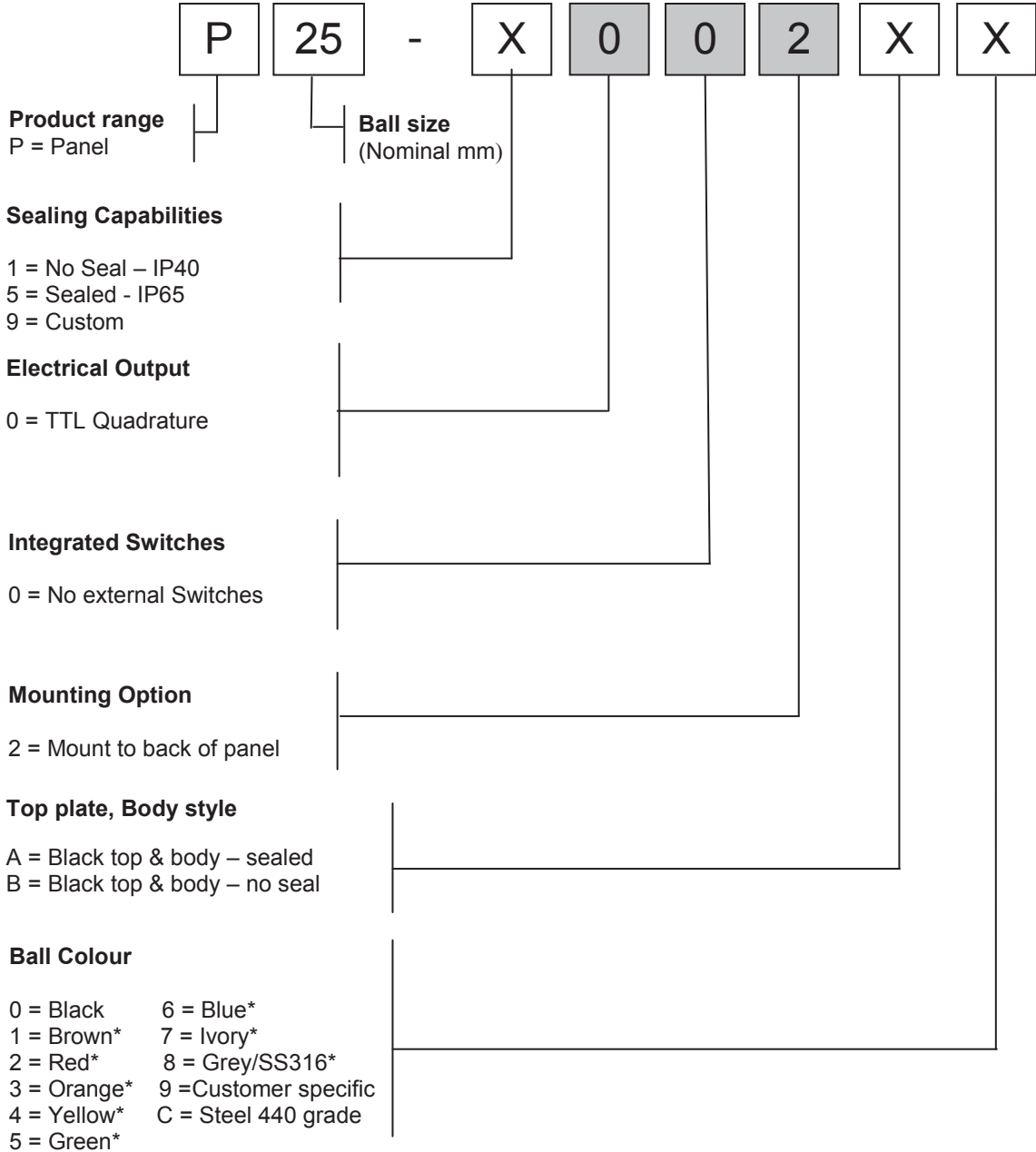

7.1 Ordering Example

P25-5002A0: Panel 25mm, sealed - IP65, TTL Quadrature, no external switches, mount to back of panel, black top & body – sealed IP65, black ball.