

M50 Series – 50mm Mechanical Trackball, Panel Mount, Protocol Output**1. DESCRIPTION**

The M50 Series mechanical trackballs are high specification modules available with a variety of electrical outputs and sealing options up to IP65.

This popular unit provides a smooth running solution for general control applications where precise cursor control is required at all times.

Manufactured using high grade stainless steel and plastic components, and incorporating the latest format of floating sealing technology, the M50 trackball will provide many years of reliable cursor control for industrial, medical and keyboard applications.

The design incorporates a removable top ring as standard to allow for easy cleaning, decontamination, sterilisation and maintenance - ensuring continued optimum performance and operation under the harshest of conditions.

The M50 Series mechanical trackballs have been designed to be back of panel mounted as part of OEM keyboards and consoles.

2. FEATURES

- Sealing up to IP65 (BS EN 60529)
- Outputs: USB & PS/2 (auto-select)
- Smooth operation in rugged environments
- Various top plate configurations providing sealing and tracking force options
- High grade stainless steel shafts and bearings
- Removable ball feature
- Custom connector options available
- Various ball colours
- Backlit ball options available

3. APPLICATIONS

- Medical systems
- Marine systems
- Navigation systems
- Sound and lighting desks
- Industrial consoles
- OEM custom solutions available

4. SPECIFICATIONS

4.1 Mechanical

Weight	~225 grams (phenolic/polyester ball) ~700 grams (stainless steel ball)
Ball	Ø50.8mm (2"), phenolic/polyester or AISI 440 stainless steel
Tracking force	~10 grams – unsealed option (IP40) (see section 8 for ordering code details) 50-80 grams – sealed option (IP54) (see section 8 for ordering code details)
Mounting position	Horizontal to 30° (non-sealed) Horizontal to 70° (IP54 sealed)
Ball load	200N (20Kg) maximum downward pressure for 2 minutes @ 20°C
Tracking engine	Dual channel photo-interrupters
Chassis material	PC/ABS
Top plate material	PC/ABS
Sealing gasket	Cellular silicone (supplied)

4.2 Electrical

Protocol	USB, PS/2 (auto-select) or SUN Systems (see section 8 for ordering code details)
Supply voltage	4.4V to 5.25V D.C.
Supply current	20mA typical, 25mA maximum
Resolution	784 counts per ball revolution (linear tracking mode)
Output connector	10 Way, right-angled JST header, part no: S10B-PH-SM3-TB
Mating output connector	10 Way JST connector, part no: PH, CR or KR types (e.g. PHR-10)
Switch Inputs	3 switches: left, middle, and right. Connection through 4-way JST, right-angled header, part no: S4B-PH-SM3-TB.
Mating switch connector	4 Way JST connector, part no: PH, CR or KR types

4.3 Environmental

Operating temperature	0°C to +55°C (IEC 60068-2-1, IEC60068-2-2)
Storage temperature	-40°C to + 85 °C (IEC 60068-2-1, IEC60068-2-2)
Operating humidity	93% RH @ 40°C, non-condensing (IEC 60068-2-78)
Storage humidity	10%-95% RH, non-condensing (IEC 60068-2-78)
Vibration	5g, 10-500Hz, 1 octave/min, 10 sweep cycles (IEC 60068-2-6)
Operating Shock	15g/11ms, ½ sine, 3 shocks in +ve and -ve direction, all 3 axes (IEC 60068-2-27)
Mechanical lifetime	1 million ball revolutions
MTBF	in excess of 80,000 hours (MIL-STD-217F)
ESD	15kV air-discharge and 8kV contact discharge (IEC 61000-4-2)
EMC	Radiated immunity - limits according to level 3 of IEC 61000-4-3 Radiated emissions to EN55022 class B
Sealing capability	Up to IP65 (BS EN 60529)

4.4 Electrical Compatibility

Windows 8, 10
Redhat Linux
Fully compliant with USB 2.0 framework (chapter 9) and HID specifications

5. CONNECTION DETAILS

Connection is made to the trackball by means of two JST connectors (or equivalent). Tables 1 and 2 highlight the connection details. Custom connections are available (please contact your local sales office for further details).

5.1 Output Connector: P1

Description: 10 way, 2mm pitch, right-angled connector
 Manufacturer: JST (or equivalent)
 Part No: S10B-PH-SM3-TB
 Mating connector: PH, CR or KR types

Pin Number	USB/PS/2
1	X1
2	X2
3	Y1
4	Y2
5	EARTH
6	0V
7	5V D.C
8	D-, PS/2 Data
9	D+, PS/2 Clock
10	0V

Table 1 Output Connections

NOTE 1: Pin to be left floating (not connected)

5.2 Switch Input Connector: P2

Description: 4 way, 2mm pitch, right-angled connector
 Manufacturer: JST (or equivalent)
 Part No: S4B-PH-SM3-TB
 Mating connector: PH, CR or KR types

Pin Number	Function
1	Left switch
2	Middle switch
3	Right switch
4	0V

Table 2 Switch Connections

5.3 Switch Schematic

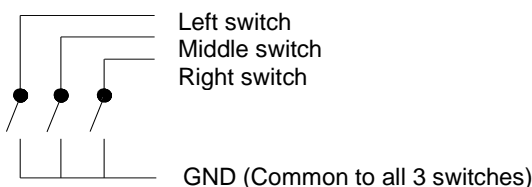

For alternative switch options and configurations please contact your local sales office.

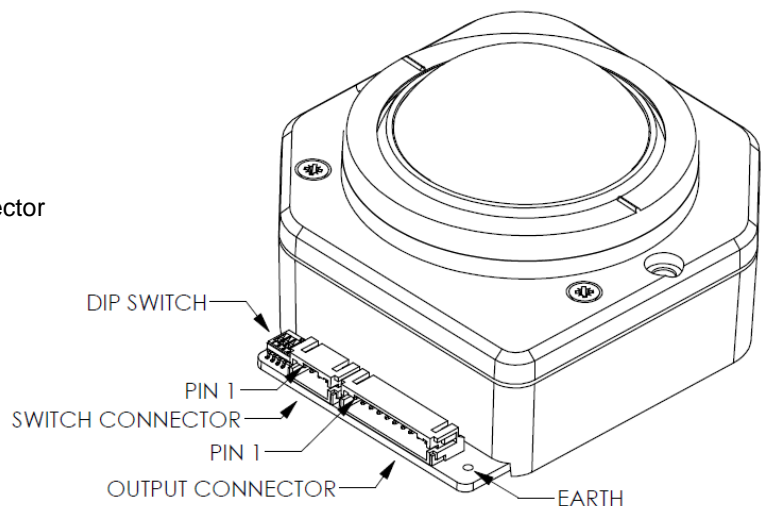

6. TRACKBALL CONFIGURATION

The M50 Series trackball provides features that may be selected using the DIP switch located on the printed circuit board. Table 3 details the assigned function of each switch.

6.1 DIP Switch Functions

DIP Switch	Function	OFF	ON
1	Orientation 1 Setting	See Figure.1	See Figure.1
2	Orientation 2 Setting	See Figure.1	See Figure.1
3	Tracking Mode	Ballistic tracking	Linear tracking
4	Factory setting	N/A	N/A

Table 3 DIP Switch Functions

Factory default setting: DIP switches all OFF

6.2 Orientation

The orientation function allows the user to mount the M50 Trackball device in one of four positions (see figure. 1 below). The orientation of the device is determined by the direction in which the output connector is facing (when viewed from the top of Trackerball device).The Trackerball orientation can be selected to accommodate customer requirements for connector location and wiring.

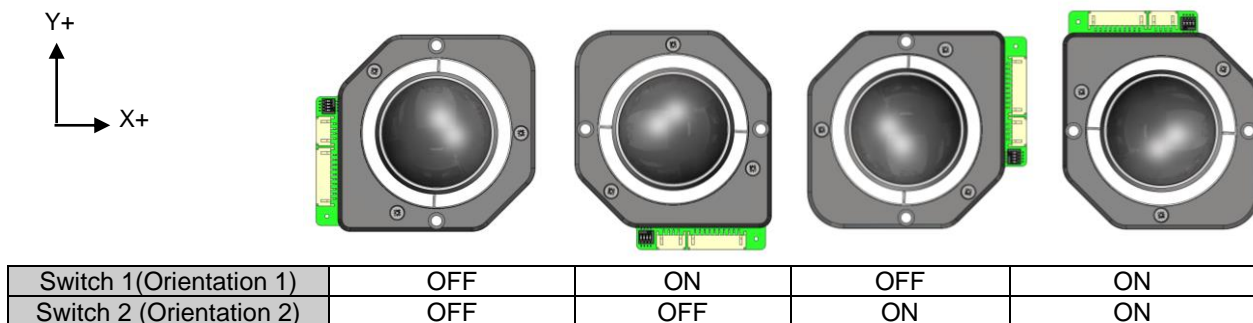

Figure 1 – Mounting Orientations

6.3 Tracking Mode

Ballistic tracking

The ballistic tracking mode is an intuitive tracking algorithm that provides increased cursor resolution with fast ball movements whilst retaining the native resolution (784 counts per revolution) at slow tracking speeds. This feature enables more efficient tracking on systems with large screens or monitors and at the same time ensures tracking accuracy is maintained at slow speeds.

The algorithm applies a gain which is directly related to the velocity of the ball and results in larger displacements of the cursor at faster ball speeds.

Linear Tracking

When the trackball is configured in linear tracking mode (DIP switch 3 ON) the data from the encoding system is transmitted to the host system with no manipulation or filtering within the trackball firmware. For example, if 3 counts of movement are generated by the encoding system, 3 counts of movement will be transmitted to the host system. In this mode one ball rotation will always generate 784 counts of movement, irrespective of the ball speed.

7. DIMENSION DRAWING

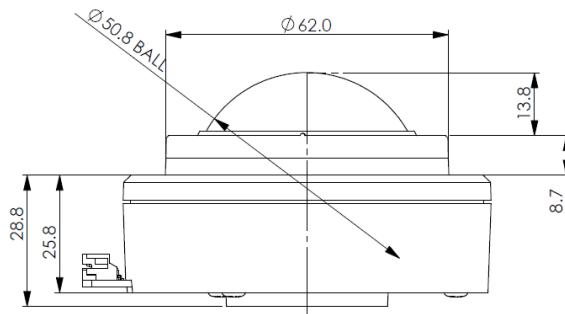
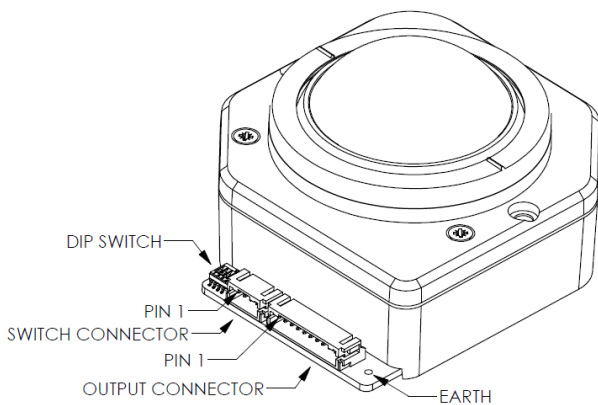
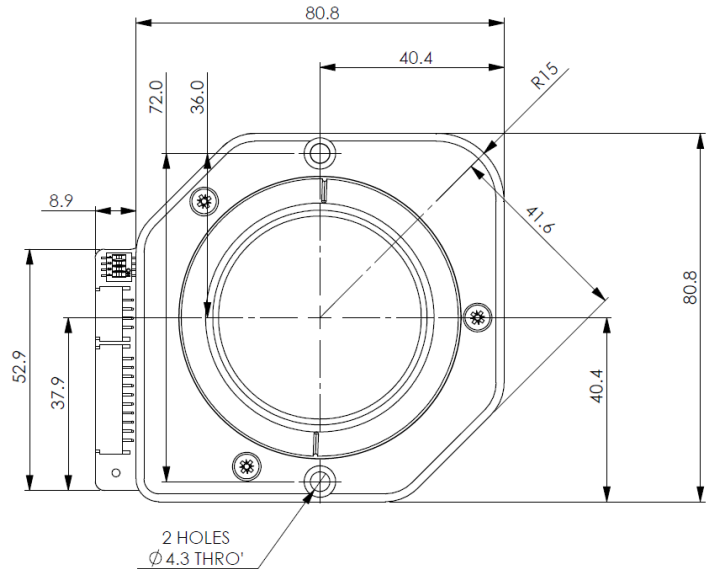
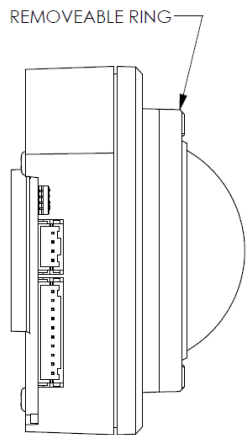

Dimensional drawing specifies factory default orientation.
 All dimensions are in mm unless otherwise stated.
 Tolerances +/- 0.2mm unless otherwise stated
 Please note that an IGES model is available on request. Please contact your local sales office for more information.

8. PRODUCT ORDERING CODE SYSTEM

Please construct your standard product ordering code by selecting the numbers and letters to suit your specification:

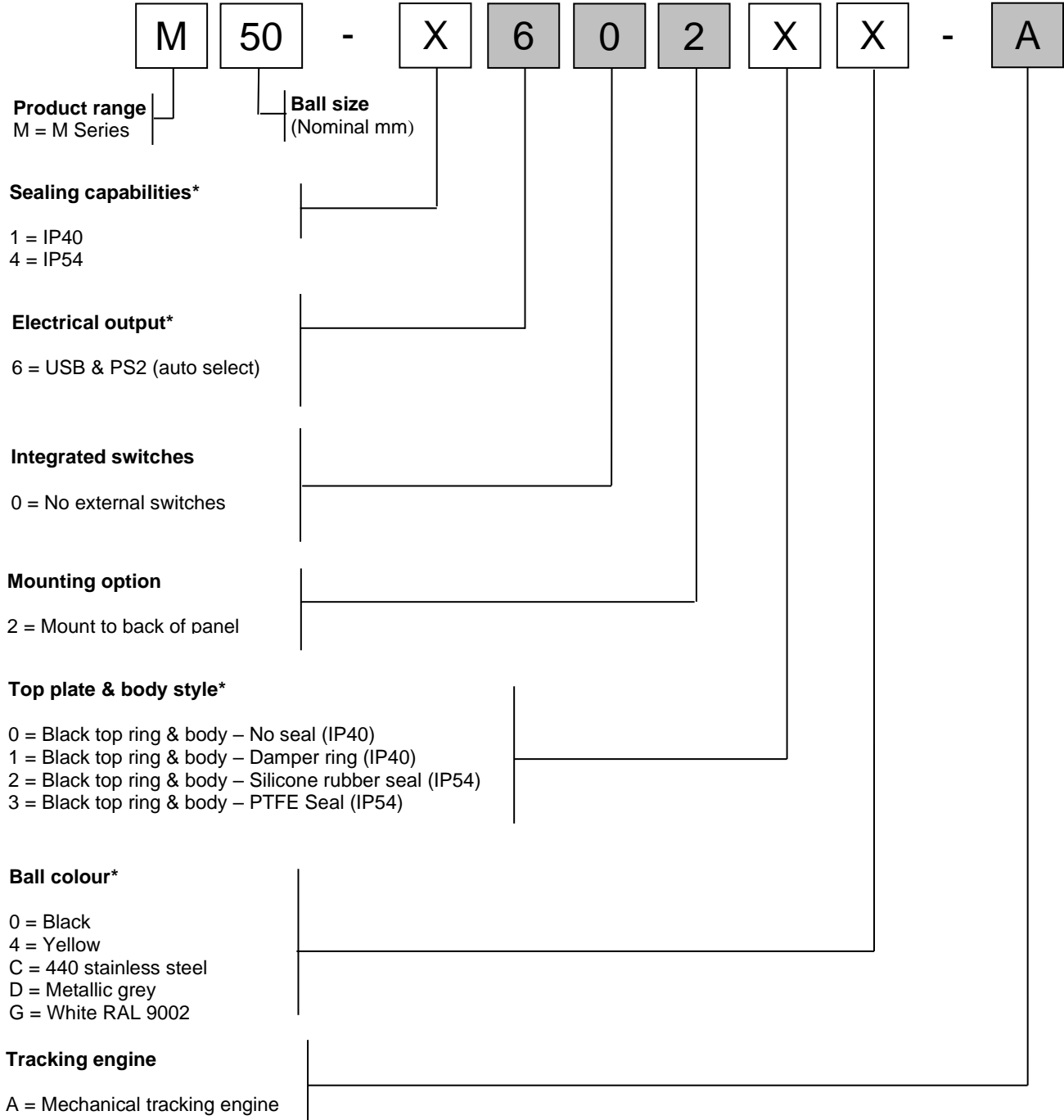

*For further options please contact your local sales representative

8.1 Ordering Example

M50-460230-A: M50, IP54, USB/PS2, no external switches, mount to back of panel, black top & body - PTFE Seal, black ball, mechanical tracking engine.

9. DOCUMENT HISTORY

Issue	Date	Author	Remarks
A	12.03.10	N.S	Document released
B	24.06.21	M.K	NP1316: Orientation section updated, SUN systems removed

Whilst the information provided herein is to the best of our knowledge true and accurate, it should be used for guidance only and may be subject to change. You are therefore advised to ensure all information provided herein is current and up to date and suitable for your application. Use of Cursor Controls Ltd products in life support systems is only permitted with prior written consent of the Company.

All information contained herein should be regarded as confidential and is supplied subject to Cursor Controls Ltd Terms and Conditions – a copy of which is available on request or can be found at www.cursorcontrols.com/terms-conditions