X50 Series – 50mm Optical Trackball, Panel Mount, USB & PS/2 Output



1. DESCRIPTION

Utilizing the latest and most advanced infrared optical tracking technology, the X50 Series optical Trackerball™ is an extremely high specification, contact-less device, ideal for the most demanding of cursor control applications.

The optical tracking engine provides accurate cursor motion at all speeds and on virtually any ball, combining the benefits of solid-state sensing (no moving parts except the ball) with the aesthetics, functionality and performance associated with the Cursor Controls product range.

The design incorporates a removable top ring as standard to allow for easy cleaning, decontamination, sterilisation and maintenance - ensuring continued optimum performance and operation under the harshest of conditions.

The X50 series trackballs are available with a variety of electrical outputs, tracking force options, and sealing capabilities up to IP68.

The trackball has been designed to be back of panel mounted as part of OEM keyboards and consoles.

2. FEATURES

- Solid state sensing technology – infrared optical tracking engine (Generation II)
- Sealing up to IP68
- Outputs: USB & PS2 (auto-select)
- Smooth operation in rugged environments
- Various top plate configurations
- Custom connector options available
- Various ball colours available
- VX3™ – integrated zoom feature for scroll wheel functionality

3. APPLICATIONS

- Medical systems
- Marine systems
- Custom keyboard applications
- Industrial consoles
- OEM custom solutions available

7. DIMENSION DRAWING

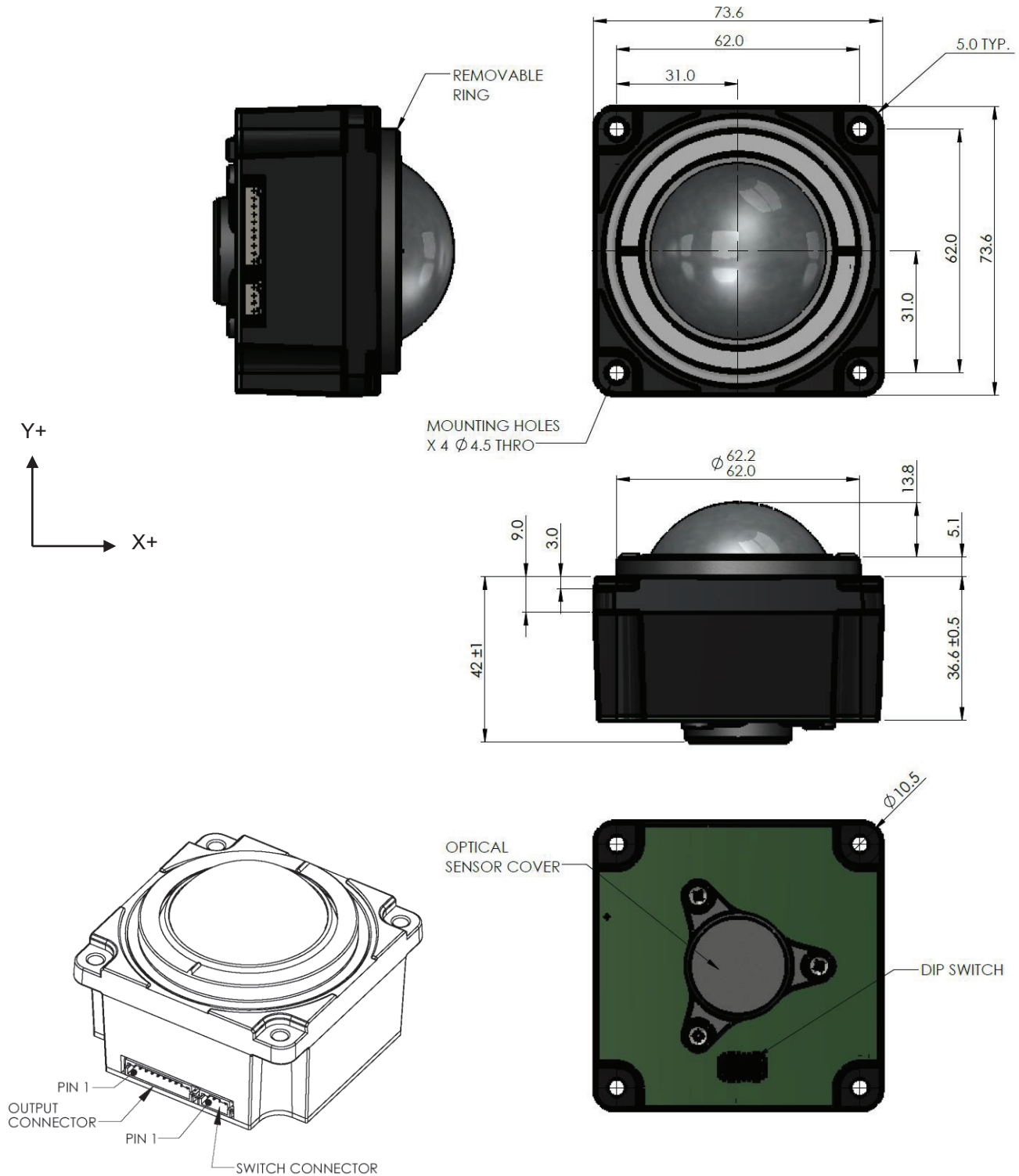

Dimensional drawing specifies factory default orientation.

All dimensions are in mm unless otherwise stated.

Tolerances +/- 0.25mm unless otherwise stated

Please note that an IGES model is available on request. Please contact your local sales office for more information.

8. PRODUCT ORDERING CODE SYSTEM

Please construct your standard product ordering code by selecting the numbers and letters to suit your specification:

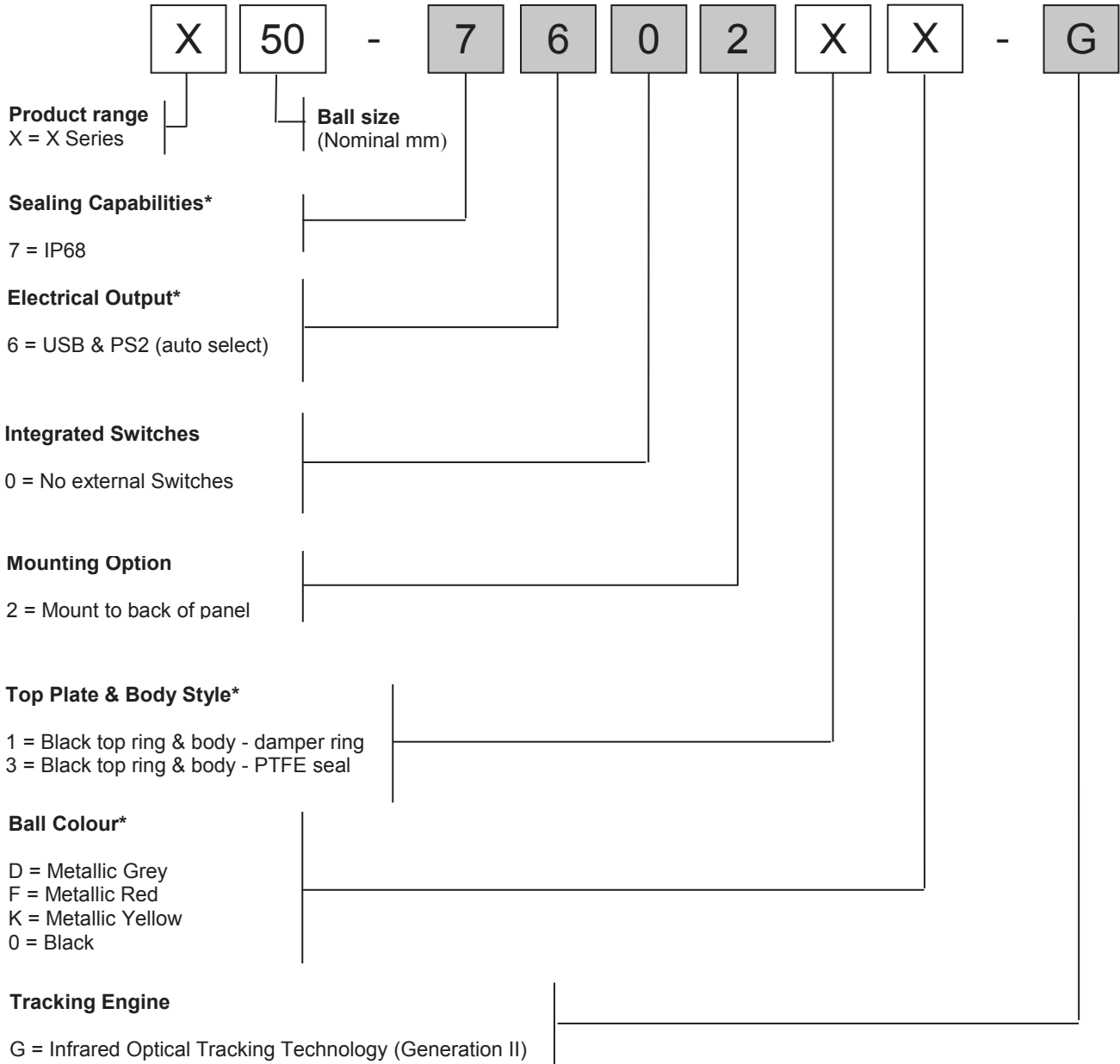

*For further options please contact your local sales representative

8.1 Ordering Example

X50-76021D-G: X50, IP68, USB & PS/2, no external switches integrated, mount to back of panel, black top ring & body - damper ring, metallic grey ball, infrared optical tracking technology (Generation II).

X50-760230-G: X50, IP68, USB & PS/2, no external switches integrated, mount to back of panel, black top ring & body – PTFE seal, black ball, infrared optical tracking technology (Generation II).