

---

---

**P50 Compact Series - Panel Mount, USB & PS/2 Output, Removable Ball**

---

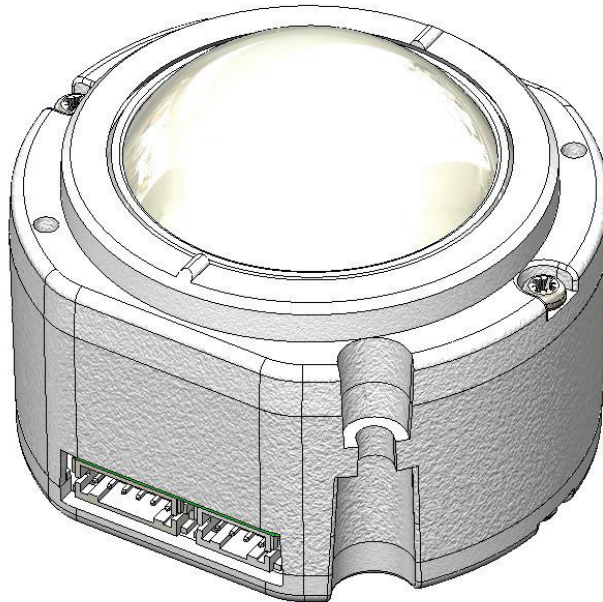

## 1. DESCRIPTION

The P50 Compact Series trackballs are low cost, high specification, professional devices for use in demanding environments.

High-grade stainless steel shafts and bearings ensure a solid and precise pointer control.

A choice of top plate and chassis configurations are available to provide various options on sealing, backlighting, bezel diameters and installation.

The unit has been designed to be back of panel mounted as part of OEM keyboards and consoles.

## 2. FEATURES

- Sealing up to IP51
- Outputs: USB & PS/2 (auto-select) or SUN Systems
- Smooth operation in rugged environments
- Stainless steel shafts and bearings
- Removable top ring and ball
- Various top plate configurations providing sealing and tracking force options
- Custom connector options
- Various ball colours available

## 3. APPLICATIONS

- Control systems
- Medical systems
- Sound and lighting desks
- Industrial consoles
- OEM custom solutions available

7. DIMENSION DRAWING

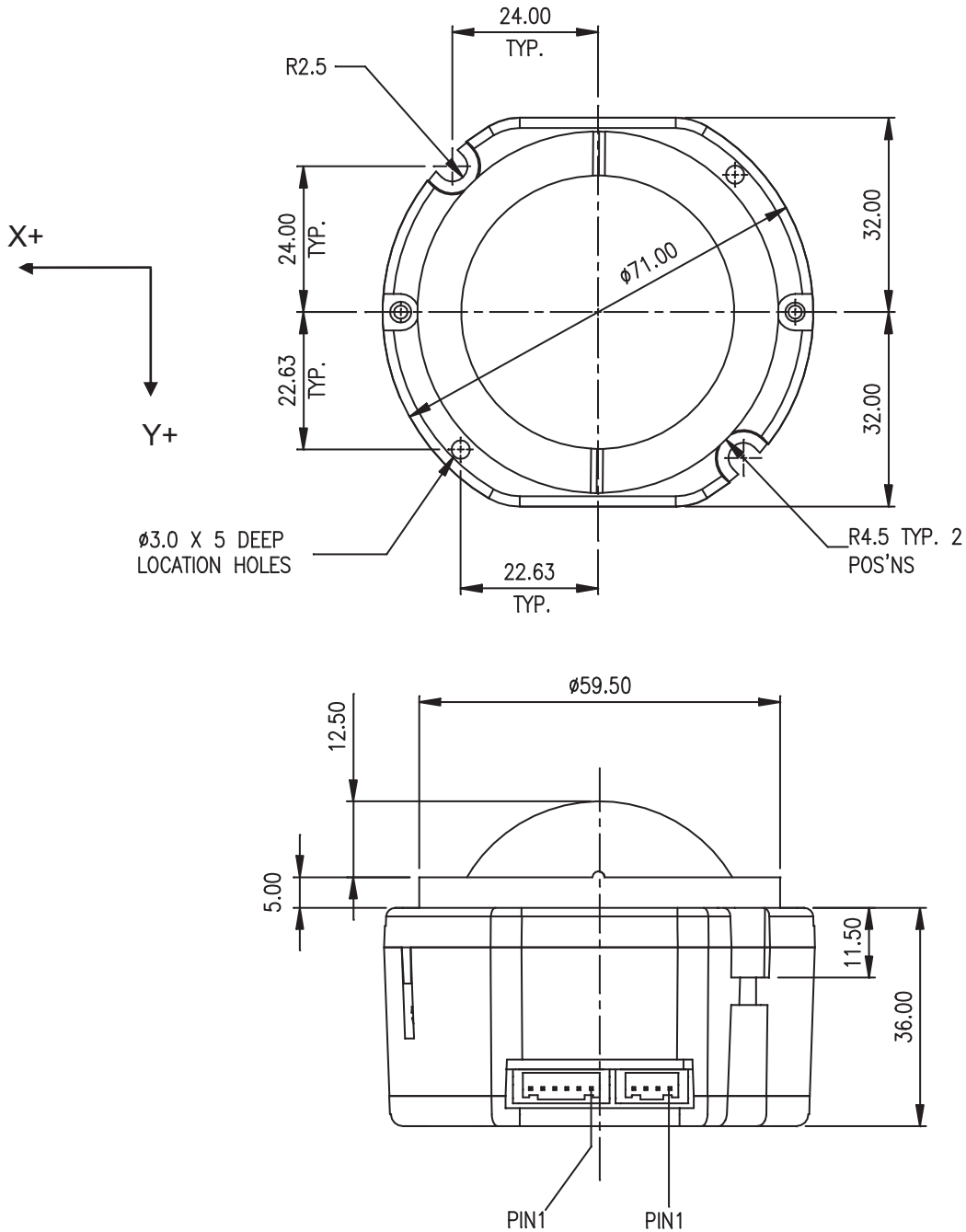

Dimensional drawing specifies factory default orientation.

All dimensions are in mm unless otherwise stated.

Tolerances +/- 0.2mm unless otherwise stated

Please note that an IGES model is available on request. Please contact your local sales office for more information

## 8. PRODUCT ORDERING CODE SYSTEM

Please construct your standard product ordering code by selecting the numbers and letters to suit your specification:

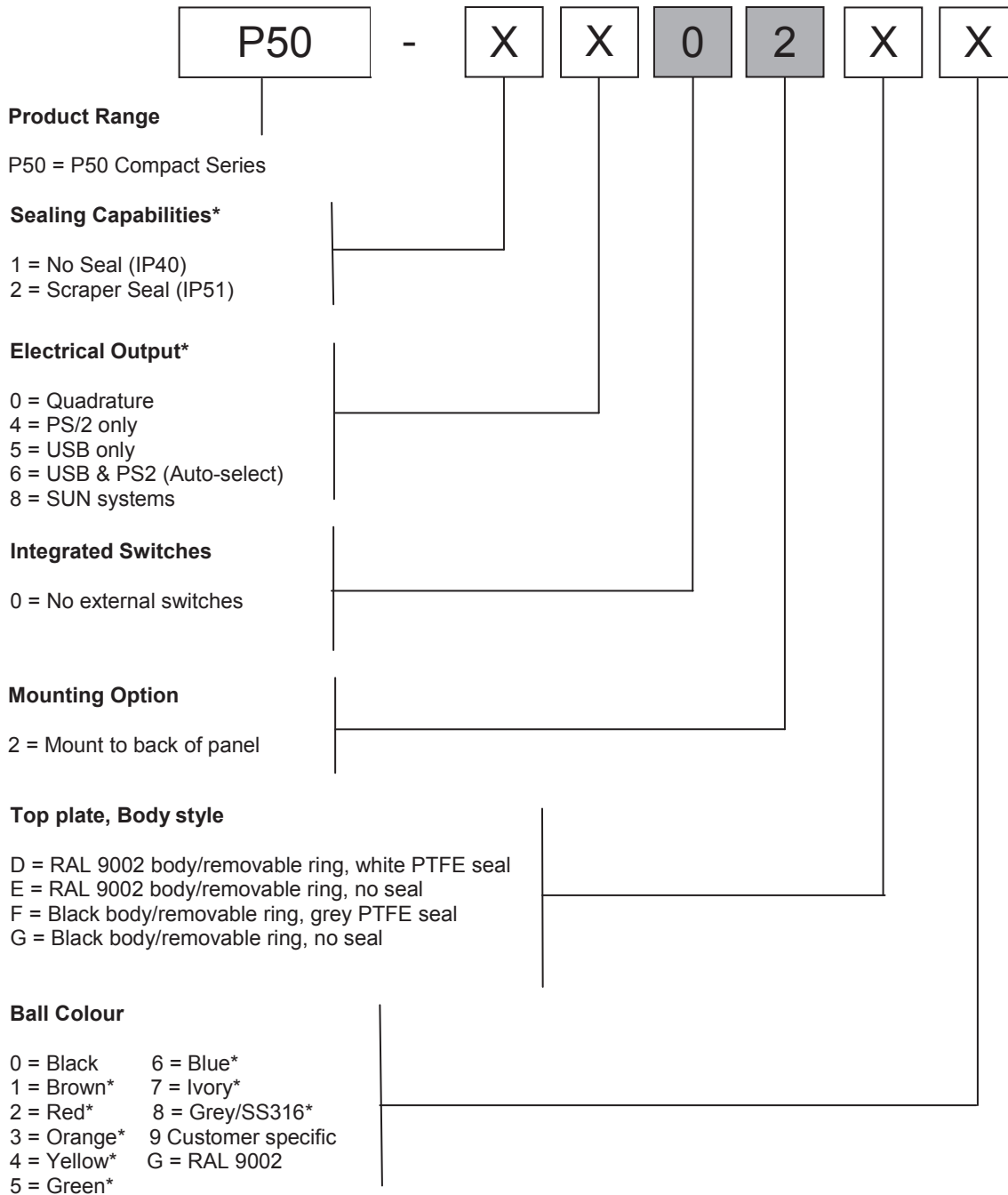

\*For further options please contact your local sales representative for further details

### 8.1 Ordering Example

**P50-2602DG:** P50 Compact Series, scraper seal (IP51), USB & PS/2, no external switches, mount to back of panel, RAL 9002 body/removable ring, white PTFE seal, RAL 9002 Ball.