

P50 Series – Anti-Vandal Trackball Assembly



1. DESCRIPTION

The P50 Series anti-vandal trackball assembly is a high specification module designed for the most demanding industrial environments.

The assembly incorporates the already well-established P50 Series trackball into a brushed stainless steel plate which is designed to be installed into a user interface panel via four welded studs.

The trackball is manufactured using high grade stainless steel and plastic components and provides a smooth running solution for applications where precise cursor tracking is required at all times.

The trackball also incorporates the latest floating sealing technology which provides IP65 sealing and ensures many years of reliable cursor control for industrial applications.

The assembly can be configured to provide various connection formats including USB & PS/2 (auto-select) and SUN Systems. Please contact your local sales representative for alternative connection formats (e.g. TTL Quadrature).

In addition, the stainless steel panel features three sealed switches with a brushed stainless steel finish that provide the conventional left, middle, and right switch functionality.

Each module is shipped with a 3 metre USB cable, a USB to PS/2 adapter, and a sealing gasket.

2. FEATURES

- 316 brushed stainless steel plate with integrated trackball
- Three integrated switches
- Sealing up to IP65 (BS EN 60529)
- Outputs: USB & PS/2 (auto-select) or SUN Systems
- Smooth operation in rugged environments
- Mechanical tracking engine - high grade stainless steel shaft and bearings
- Various ball colours/materials available
- VX3™ – integrated zoom feature for scroll wheel functionality

3. APPLICATIONS

- Industrial control panels
- Military/Marine/Medical user interface panels
- Public access kiosks
- OEM custom solutions available

8. DIMENSION DRAWING

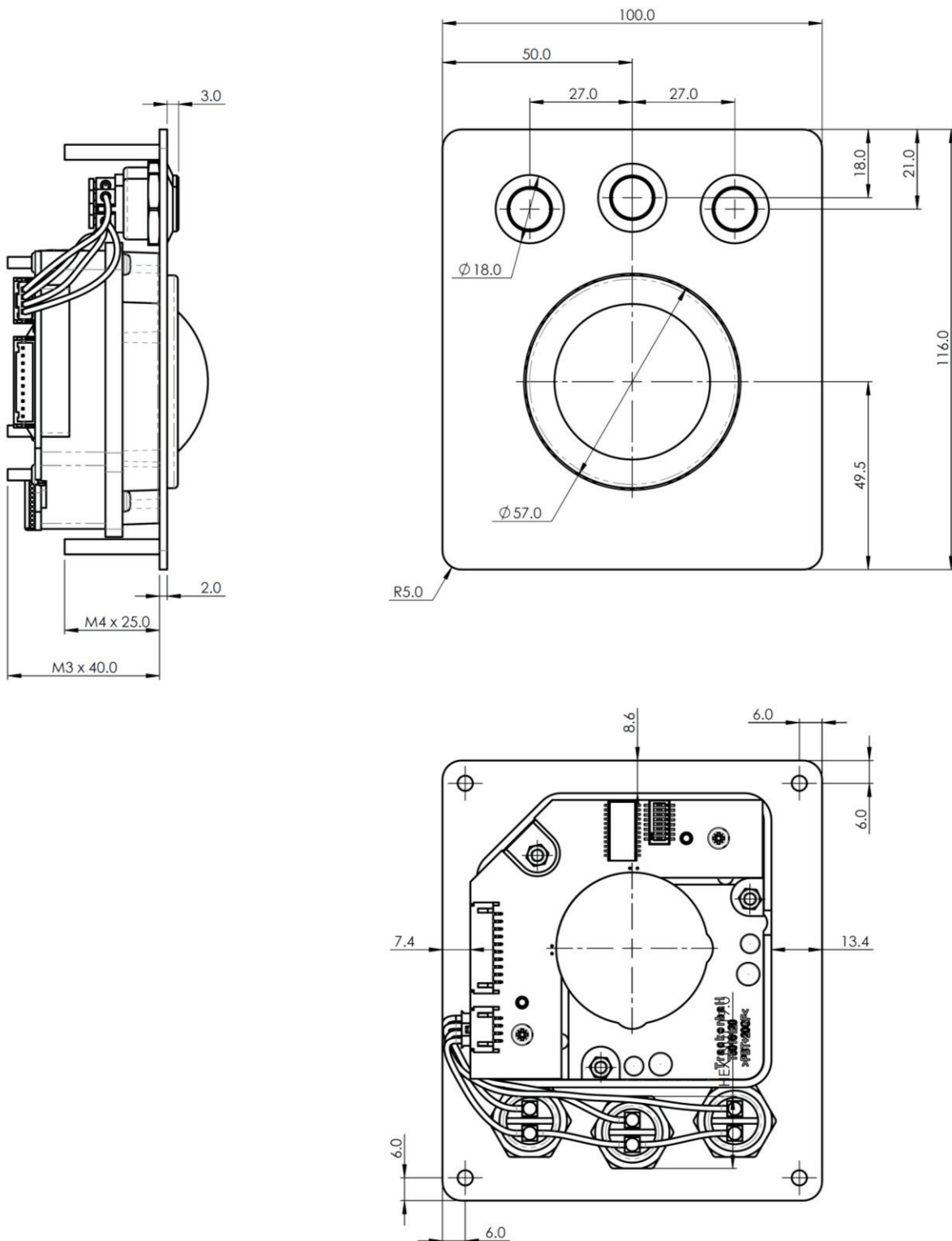

Dimensional drawing specifies factory default orientation.
 All dimensions are in mm unless otherwise stated.
 Tolerances +/- 0.2mm unless otherwise stated
 Please note that an IGES model is available on request. Please contact your local sales office for more information.

10. PRODUCT ORDERING CODE SYSTEM

Please construct your standard product ordering code by selecting the numbers and letters to suit your specification:

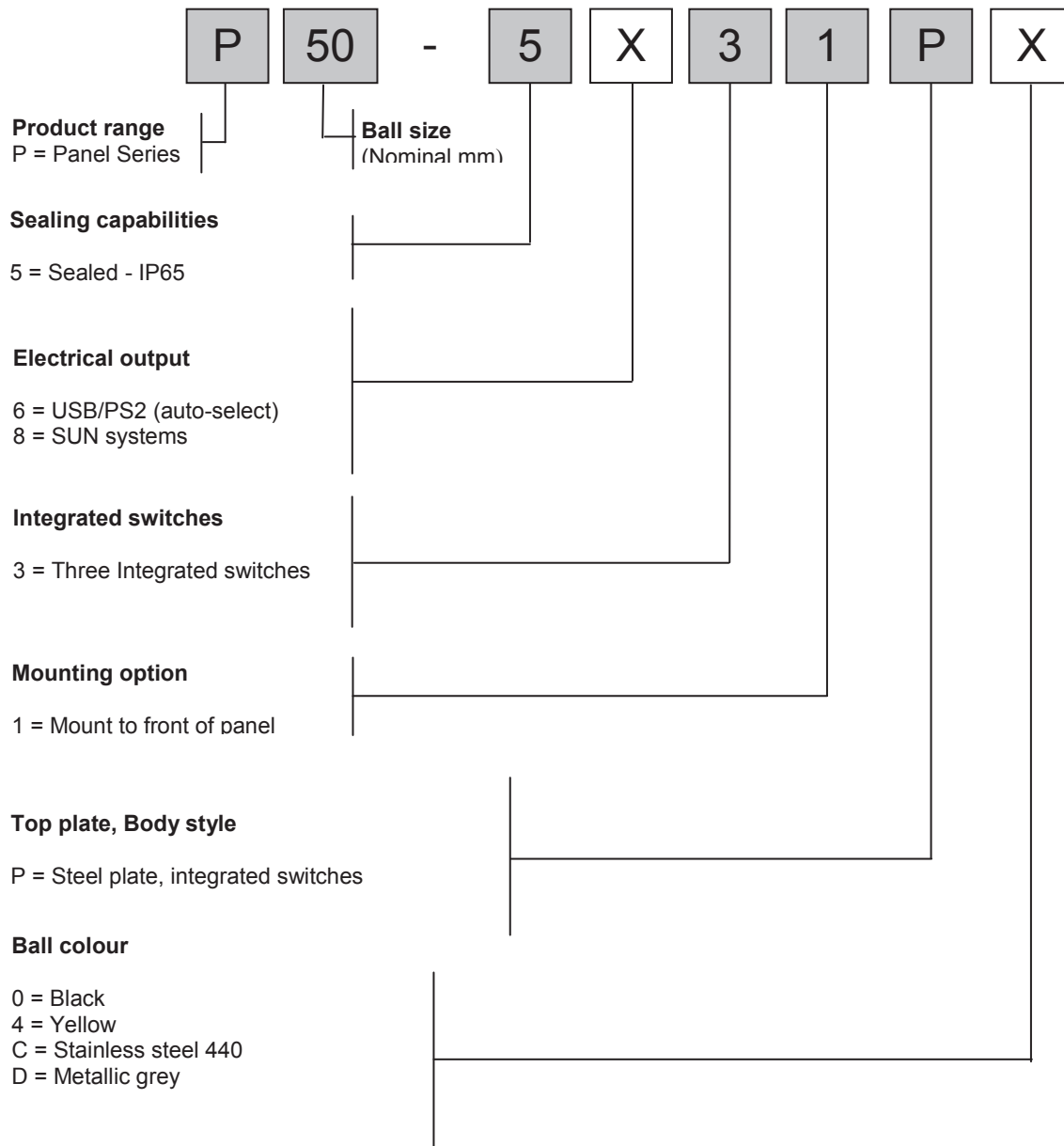

For further options on ball colours please contact your local sales representative

10.1 Ordering Example

P50-5631P0: Panel 50mm, IP65, USB & PS/2, 3 integrated switches, mount to front of panel, steel plate, integrated switches, and black ball.

P50-5631P4: Panel 50mm, IP65, USB & PS/2, 3 integrated switches, mount to front of panel, steel plate, integrated switches, and yellow ball.