

P50 Series - Panel Mount Trackball, USB & PS/2 or SUN Systems Output, Sealed/non-Sealed, RGB LED illuminated Ball

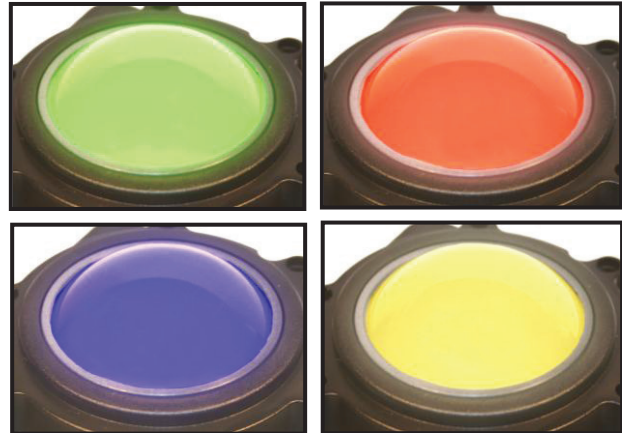

Non-illuminated ball



Illuminated ball

1. DESCRIPTION

The P50 RGB mechanical trackball is a high specification module which offers complete independent control of the integrated RGB LEDs to provide various options for ball illumination colour/intensity. The P50 RGB trackball is also available with a variety of electrical outputs and sealing options up to IP65.

This popular unit provides a smooth running solution for general control applications where precise cursor control is required at all times.

Manufactured using high grade stainless steel and plastic components, and incorporating the latest format of floating sealing technology, the P50 RGB trackball will provide many years of reliable cursor control for industrial, medical and keyboard applications.

The P50 RGB trackball has been designed to be back panel mounted as part of OEM keyboards and consoles for use in low light level environments.

2. FEATURES

- Sealing up to IP65 (BS EN 60529)
- Outputs: USB & PS/2 or SUN Systems
- RGB LED illuminated ball - independent colour/intensity control
- Smooth operation in rugged environments
- Various top plate configurations providing sealing and tracking force options
- High grade stainless steel shaft and bearings
- Custom connector options
- VX3™ – integrated zoom feature for scroll wheel functionality

3. APPLICATIONS

- Control systems
- Medical systems
- Marine systems
- Navigation systems
- Sound and lighting desks
- Industrial consoles
- OEM custom solutions available

11. DIMENSION DRAWING

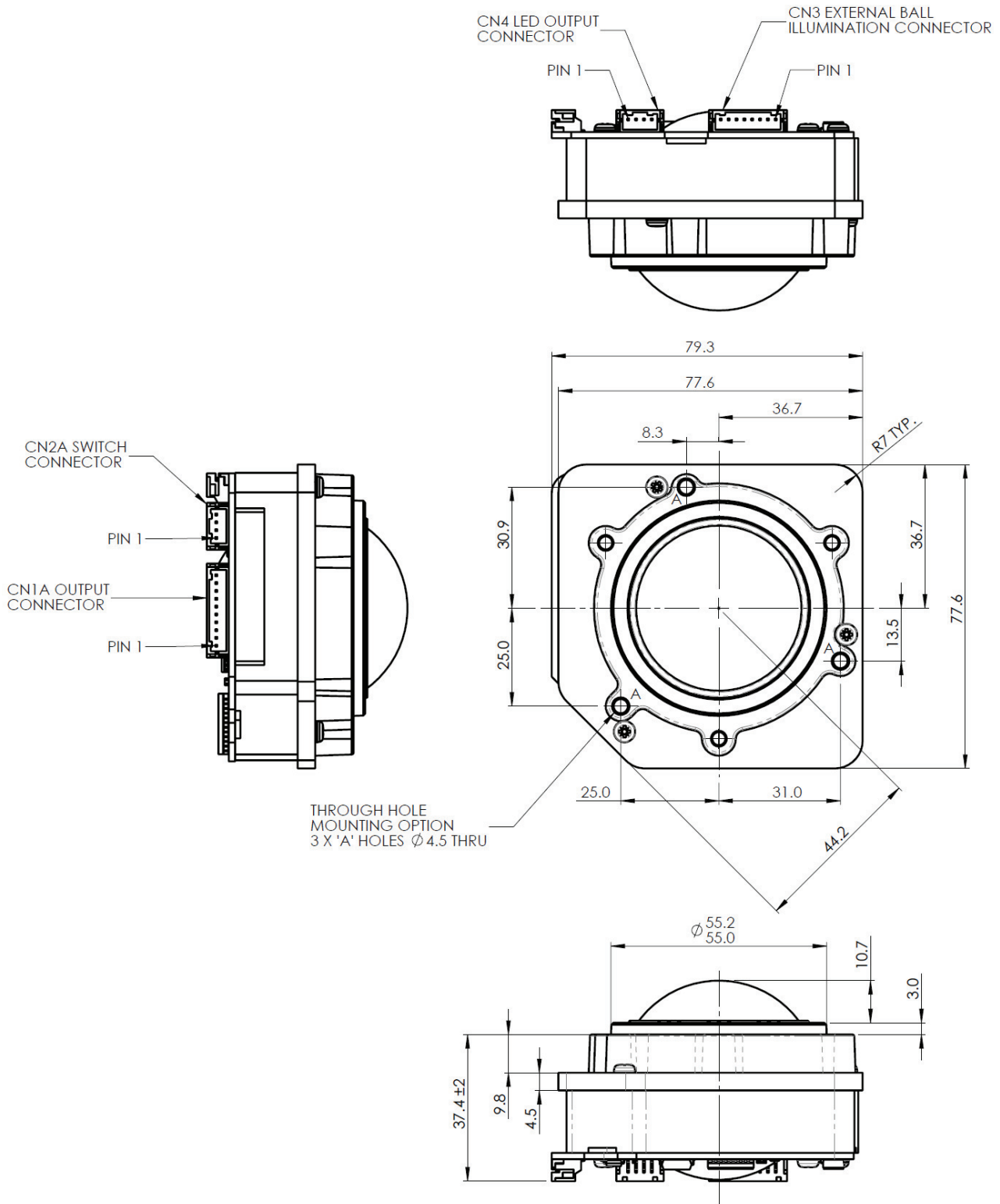

Dimensional drawing specifies factory default orientation.

All dimensions are in mm unless otherwise stated.

Tolerances +/- 0.2mm unless otherwise stated

Please note that an IGES model is available on request. Please contact your local sales office for more information.

12. PRODUCT ORDERING CODE SYSTEM

Please construct your standard product ordering code by selecting the numbers and letters to suit your specification:

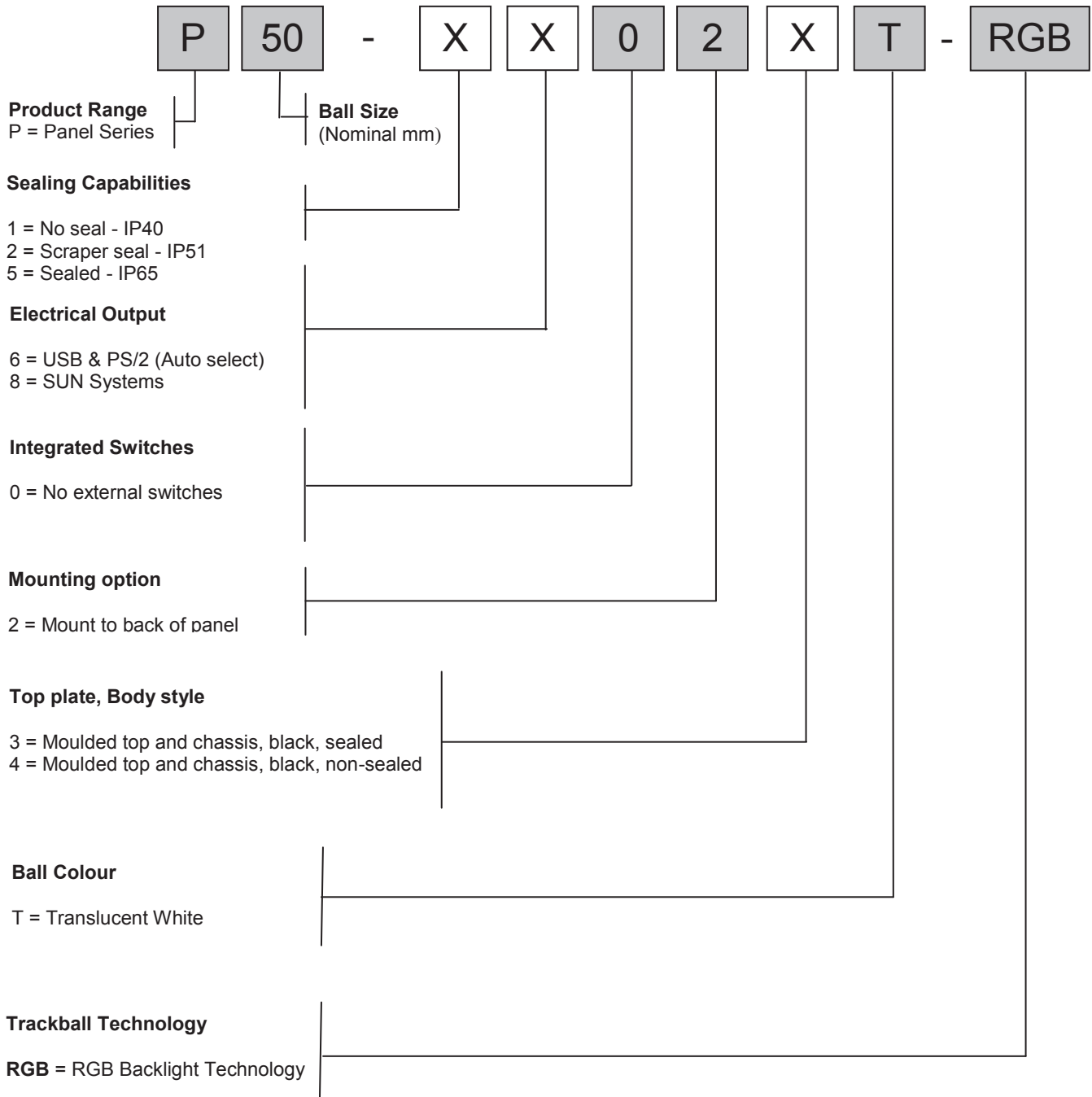

12.1 Ordering Example

P50-56023T-RGB: Panel 50mm, IP65, USB & PS/2, no external switches, mount to back of panel, Moulded top and chassis, black, sealed, translucent white ball, RGB backlight technology.

P50-18024T-RGB: Panel 50mm, IP40, Sun Systems, no external switches, mount to back of panel, Moulded top and chassis, black, non-sealed, translucent white ball, RGB backlight technology.