P50 Series - Panel Mount Trackball, Protocol Output, Stainless Steel Trim



1. DESCRIPTION

The P50 Series mechanical trackballs are high specification modules available with a variety of electrical outputs and sealing options up to IP65.

This popular unit provides a smooth running solution for general control applications where precise cursor control is required at all times.

Manufactured using high grade stainless steel and plastic components, and incorporating the latest format of floating sealing technology, the P50 Trackball will provide many years of reliable cursor control for industrial, medical and keyboard applications.

The stainless steel trim also provides an extra degree of protection in public access points where vandal attacks are commonplace.

The P50 Series trackballs have been designed to be back of panel mounted as part of OEM keyboards and consoles.

2. FEATURES

- Sealing up to IP65 (BS EN 60529)
- Outputs: PS/2, USB, SUN
- Stainless steel trim for enhanced protection in extreme environments
- Smooth operation in rugged environments
- Various top plate configurations providing sealing and tracking force options
- High grade stainless steel shaft and bearings
- Custom connector options
- Various ball colours
- VX3™ – integrated zoom feature for scroll wheel functionality

3. APPLICATIONS

- Control systems
- Medical systems
- Marine systems
- Navigation systems
- Sound and lighting desks
- Industrial consoles
- OEM custom solutions available

7. DIMENSION DRAWING

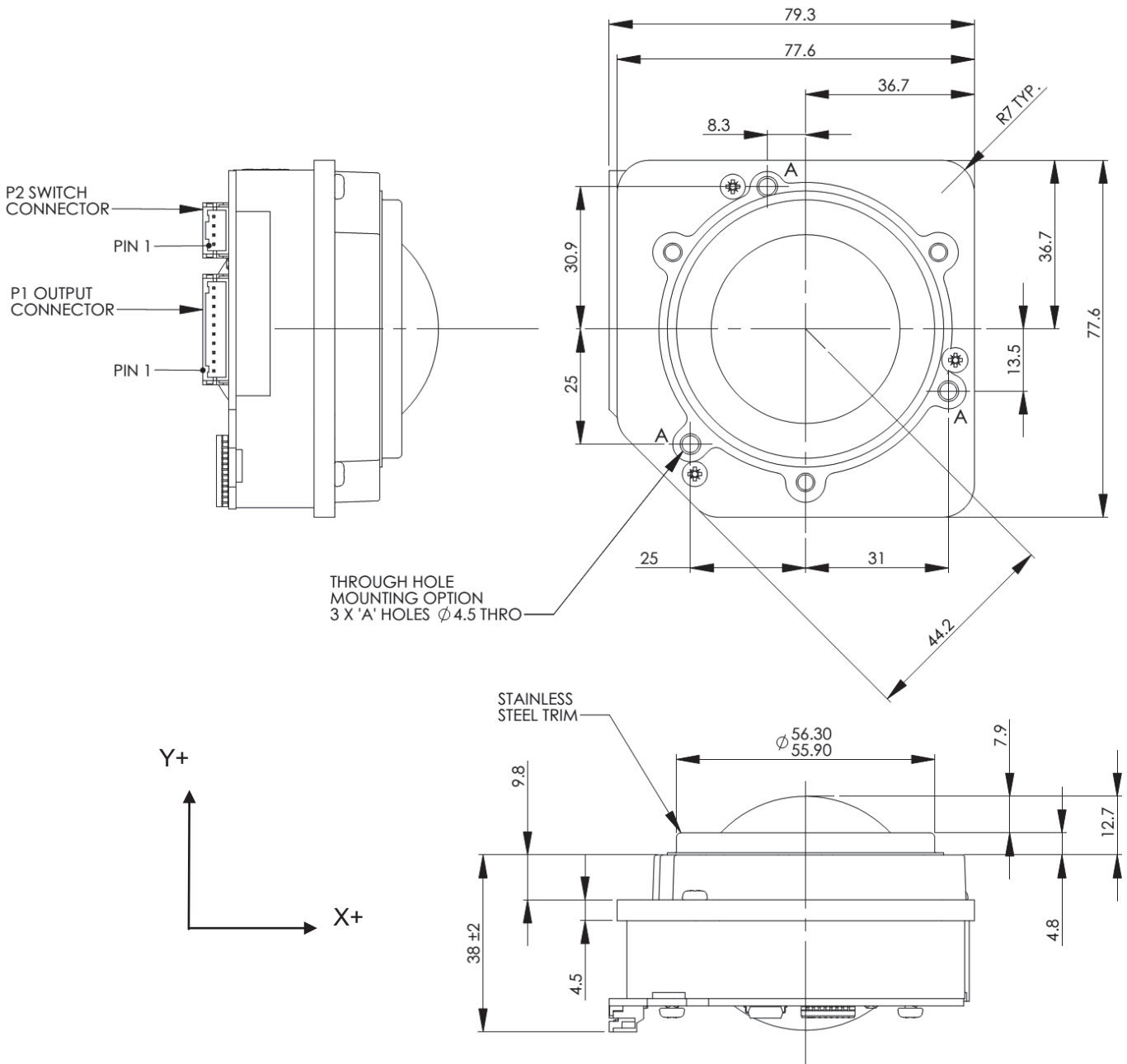

Dimensional drawing specifies factory default orientation.

All dimensions are in mm unless otherwise stated.

Tolerances +/- 0.2mm unless otherwise stated

Please note that an IGES model is available on request. Please contact your local sales office for more information.

8. PRODUCT ORDERING CODE SYSTEM

Please construct your standard product ordering code by selecting the numbers and letters to suit your specification:

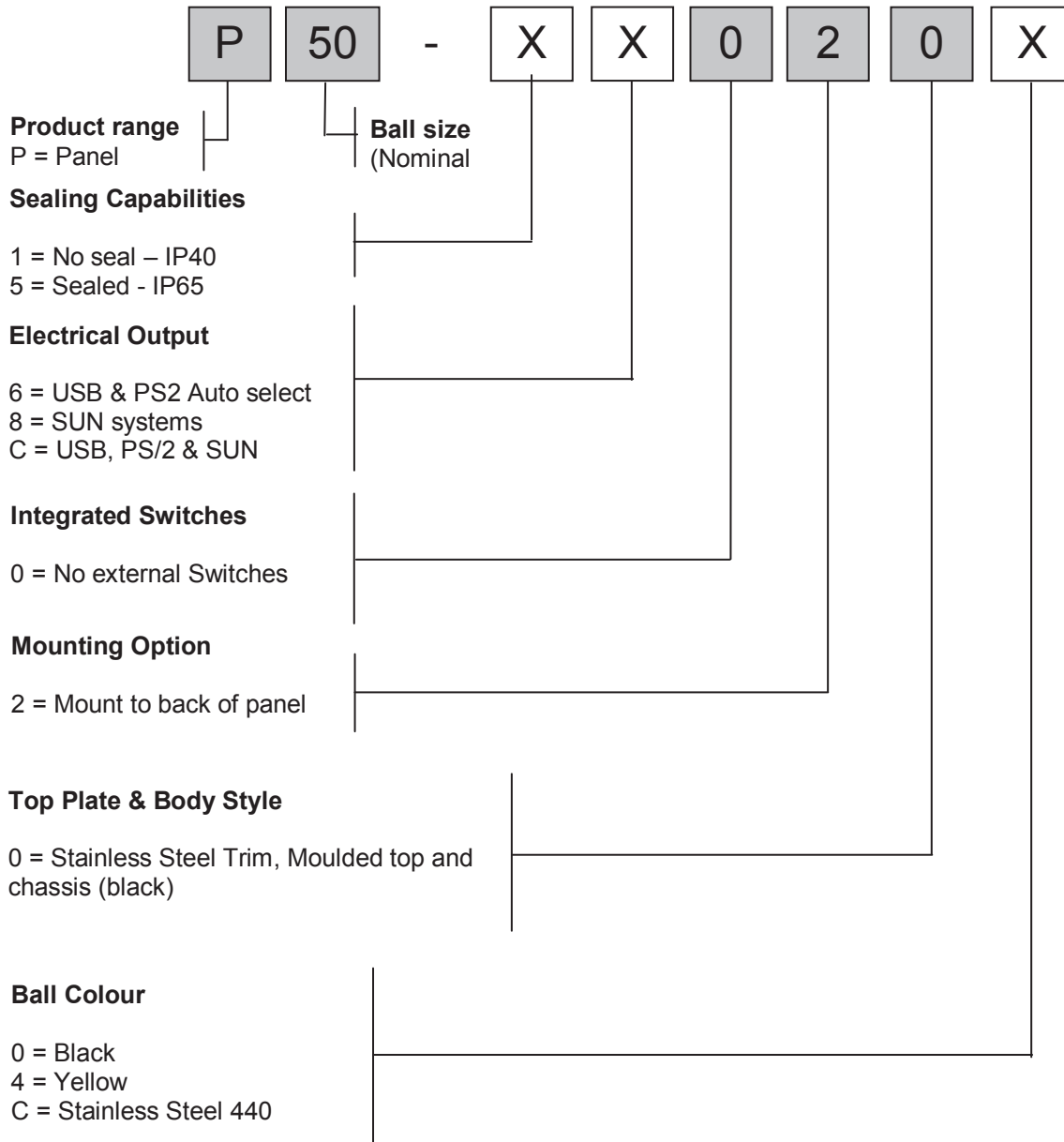

*Non standard colour – MOQ and lead-time may apply
For further options on ball colours please contact your local sales representative

8.1 Ordering Example

P50-56020C: Panel 50mm, IP65, USB & PS/2, no switches, mount to back of panel, stainless steel trim, moulded top and chassis (black), stainless steel ball