M50 Series – 50mm Mechanical Trackball, Panel Mount, Quadrature Output



1. DESCRIPTION

The M50 Series mechanical trackballs are high specification modules available with a variety of electrical outputs and sealing options up to IP65.

This popular unit provides a smooth running solution for general control applications where precise cursor control is required at all times.

Manufactured using high grade stainless steel and plastic components, and incorporating the latest format of floating sealing technology, the M50 trackball will provide many years of reliable cursor control for industrial, medical and keyboard applications.

The design incorporates a removable top ring as standard to allow for easy cleaning, decontamination, sterilisation and maintenance - ensuring continued optimum performance and operation under the harshest of conditions.

The M50 Series mechanical trackballs have been designed to be back of panel mounted as part of OEM keyboards and consoles.

2. FEATURES

- Sealing up to IP65 (BS EN 60529)
- Outputs: TTL Quadrature
- Smooth operation in rugged environments
- Various top plate configurations providing sealing and tracking force options
- High grade stainless steel shafts and bearings
- Removable ball feature
- Custom connector options available
- Various ball colours
- Backlit ball options available

3. APPLICATIONS

- Medical systems
- Marine systems
- Navigation systems
- Sound and lighting desks
- Industrial consoles
- OEM custom solutions available

6. DIMENSION DRAWING

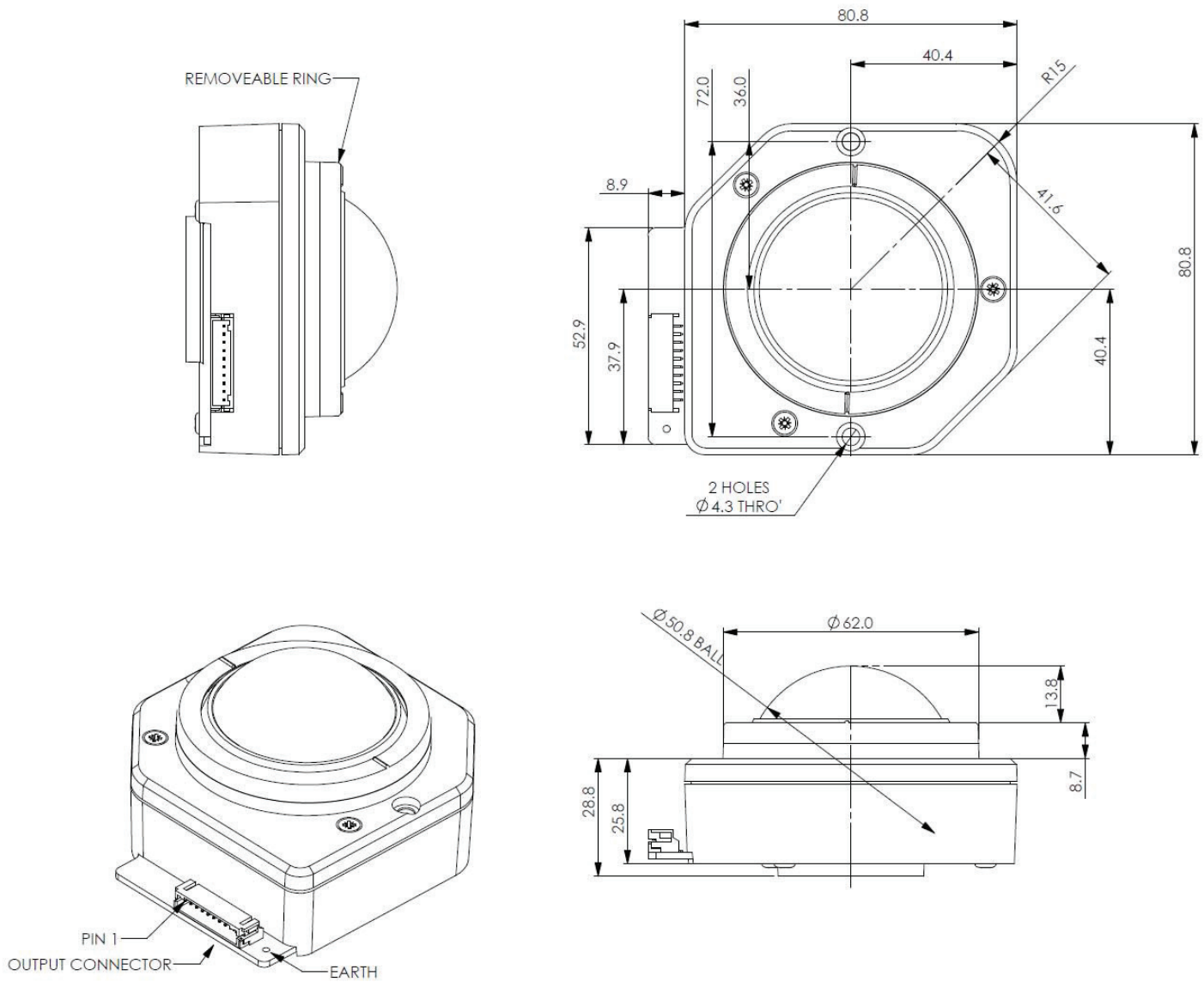

Dimensional drawing specifies factory default orientation.
 All dimensions are in mm unless otherwise stated.
 Tolerances +/- 0.2mm unless otherwise stated
 Please note that an IGES model is available on request. Please contact your local sales office for more information.

7. PRODUCT ORDERING CODE SYSTEM

Please construct your standard product ordering code by selecting the numbers and letters to suit your specification:

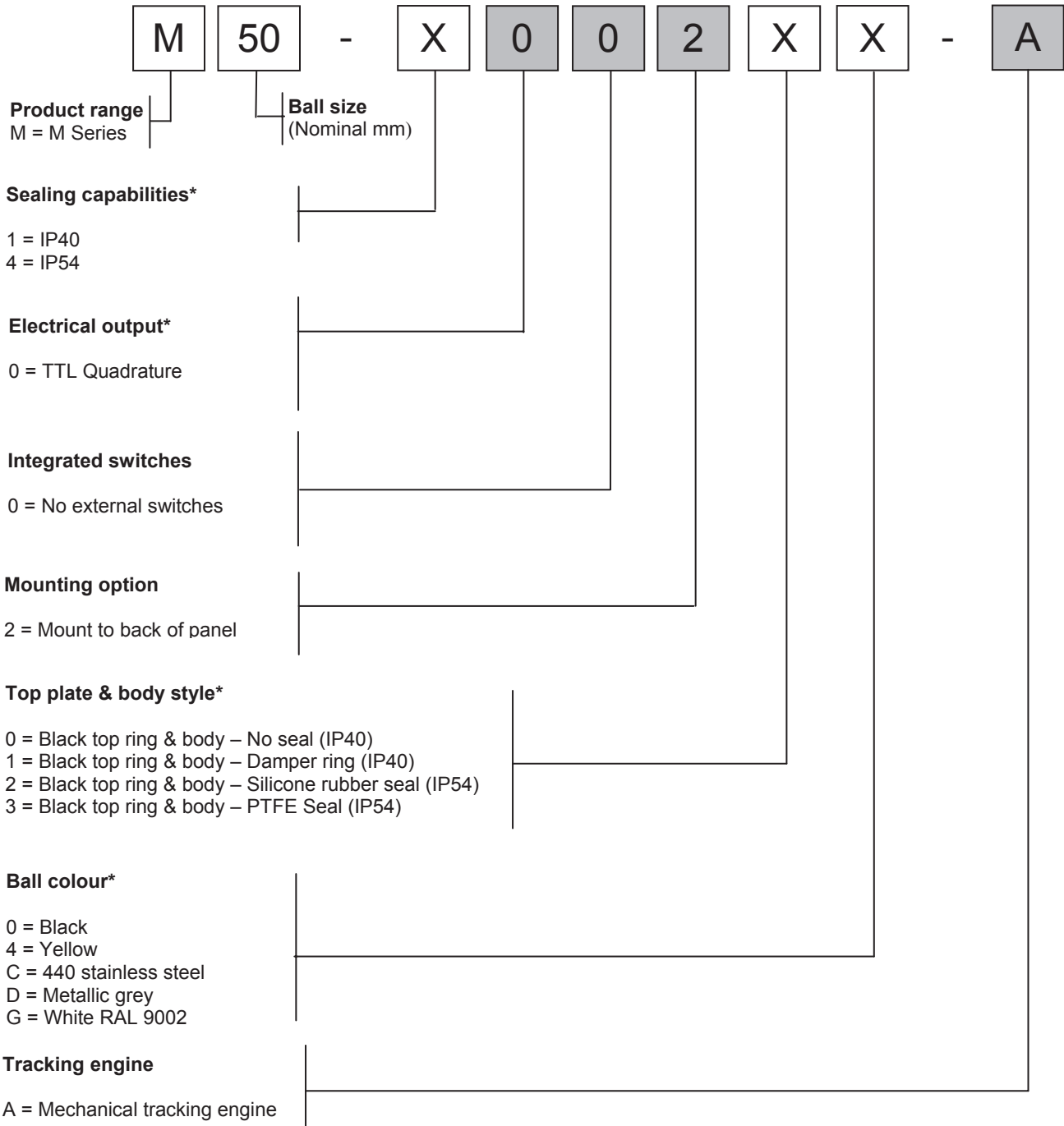

*For further options please contact your local sales representative

7.1 Ordering Example

M50-400230-A: M50, IP54, TTL Quadrature, no external switches, mount to back of panel, black top & body - PTFE seal, black ball, mechanical tracking engine