

C50 Series - Laser Trackball, Panel Mount, USB & PS/2 Output



1. DESCRIPTION

Utilizing the latest and most advanced laser tracking technology, the C50 Series laser Trackerball™ is an extremely high specification, contact-less device, ideal for the most demanding of cursor control applications.

The laser tracking engine provides accurate cursor motion at all speeds and on virtually any ball, combining the benefits of solid state sensing (no moving parts except the ball) with the aesthetics, functionality and performance associated with the Cursor Controls product range.

The design incorporates a removable top ring as standard to allow for easy cleaning, decontamination, sterilisation and maintenance - ensuring continued optimum performance and operation under the harshest of conditions.

The C50 Series trackballs are available with a variety of electrical outputs and tracking force options. The trackball has been designed to be back of panel mounted as part of OEM keyboards and consoles.

2. FEATURES

- Solid state sensing technology – laser tracking engine
- Outputs: USB & PS2 (auto-select) or SUN Systems
- Smooth operation in rugged environments
- Various top plate configurations
- Custom connector options available
- Various ball colours available

3. APPLICATIONS

- Medical systems
- Marine systems
- Custom keyboard applications
- Industrial consoles
- OEM custom solutions available

7. DIMENSION DRAWING

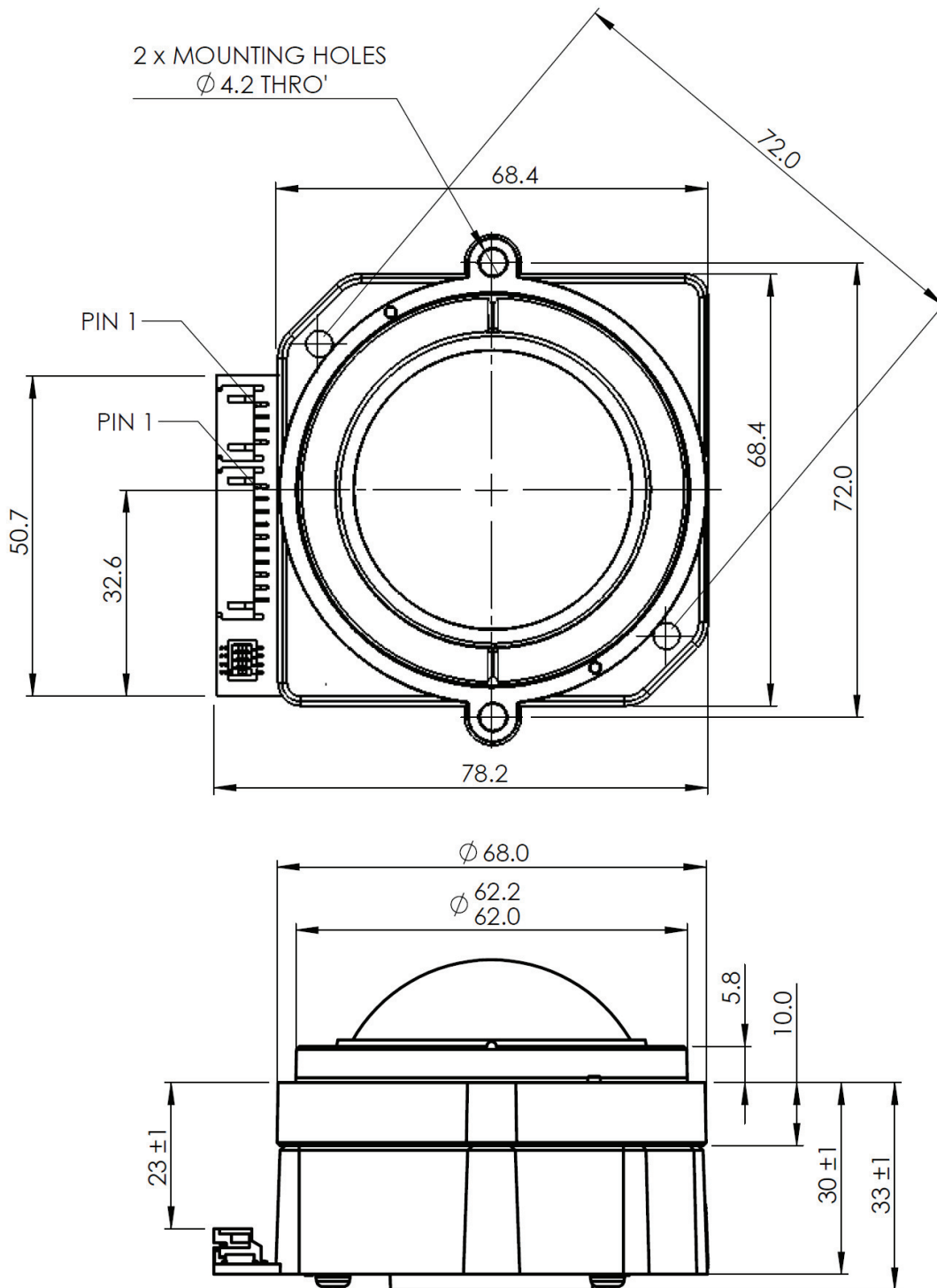

Dimensional drawing specifies factory default orientation.

All dimensions are in mm unless otherwise stated.

Tolerances ± 0.2 mm unless otherwise stated

Please note that an IGES model is available on request. Please contact your local sales office for more information.

9. PRODUCT ORDERING CODE SYSTEM

Please construct your standard product ordering code by selecting the numbers and letters to suit your specification:

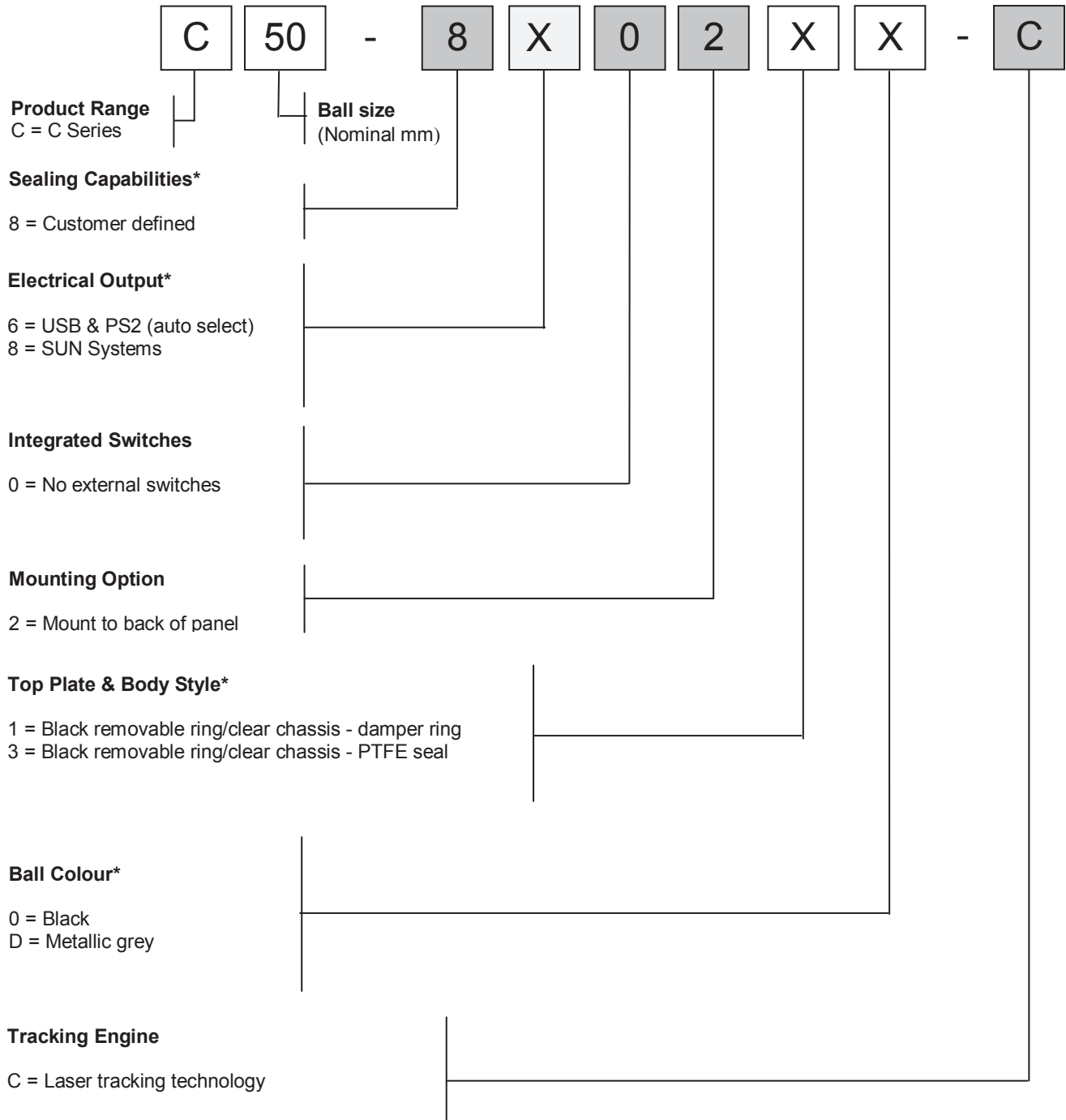

*For further options please contact your local sales representative

9.1 Ordering Example

C50-86021D-C: C50, customer defined sealing, USB & PS/2 output, no switches, mount to back of panel, black removable ring/clear chassis - damper ring, metallic grey ball, laser tracking technology