

## Z50 Series – Ø50mm Optical Trackball, Panel Mount, Quadrature Output



### 1. DESCRIPTION

Utilizing the latest and most advanced optical tracking technology, the Z50 low profile Optical Trackerball™ is an extremely high specification, contact-less device, ideal for the most demanding of cursor control applications. The device provides both conventional X and Y axis cursor movement with an additional Z axis control wheel surrounding the ball.

The optical tracking engine provides accurate cursor motion at all speeds and combines the benefits of solid state sensing (no moving parts except the ball) with the aesthetics, functionality and performance associated with the Cursor Controls product range.

The unit has been designed to be back of panel mounted as part of OEM keyboards and consoles.

### 2. FEATURES

- Solid state sensing technology – optical tracking engine
- Z-axis control wheel for scroll/zoom capability
- Output: TTL Quadrature
- Smooth operation in rugged environments
- Various top plate configurations available
- Custom connector options available

### 3. APPLICATIONS

- Sound and lighting desks
- Video editing consoles
- Medical systems
- Marine systems
- Custom keyboard applications
- Industrial consoles

8. DIMENSION DRAWING

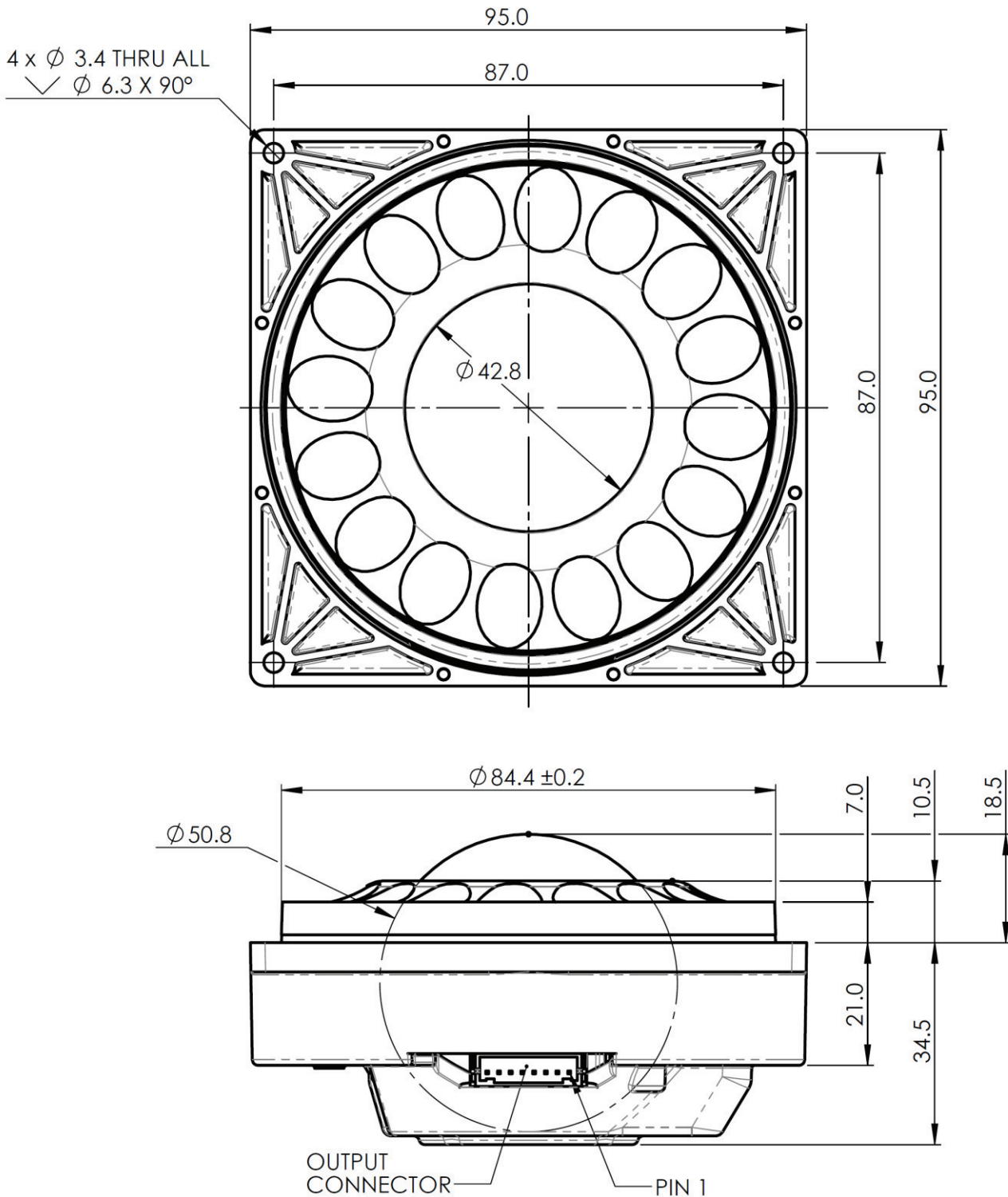

Dimensional drawing specifies factory default orientation.

All dimensions are in mm unless otherwise stated.

Tolerances  $\pm$  0.2mm unless otherwise stated

Please note that an IGES model is available on request. Please contact your local sales office for more information.

### 9. PRODUCT ORDERING CODE SYSTEM

Please construct your standard product ordering code by selecting the numbers and letters to suit your specification:

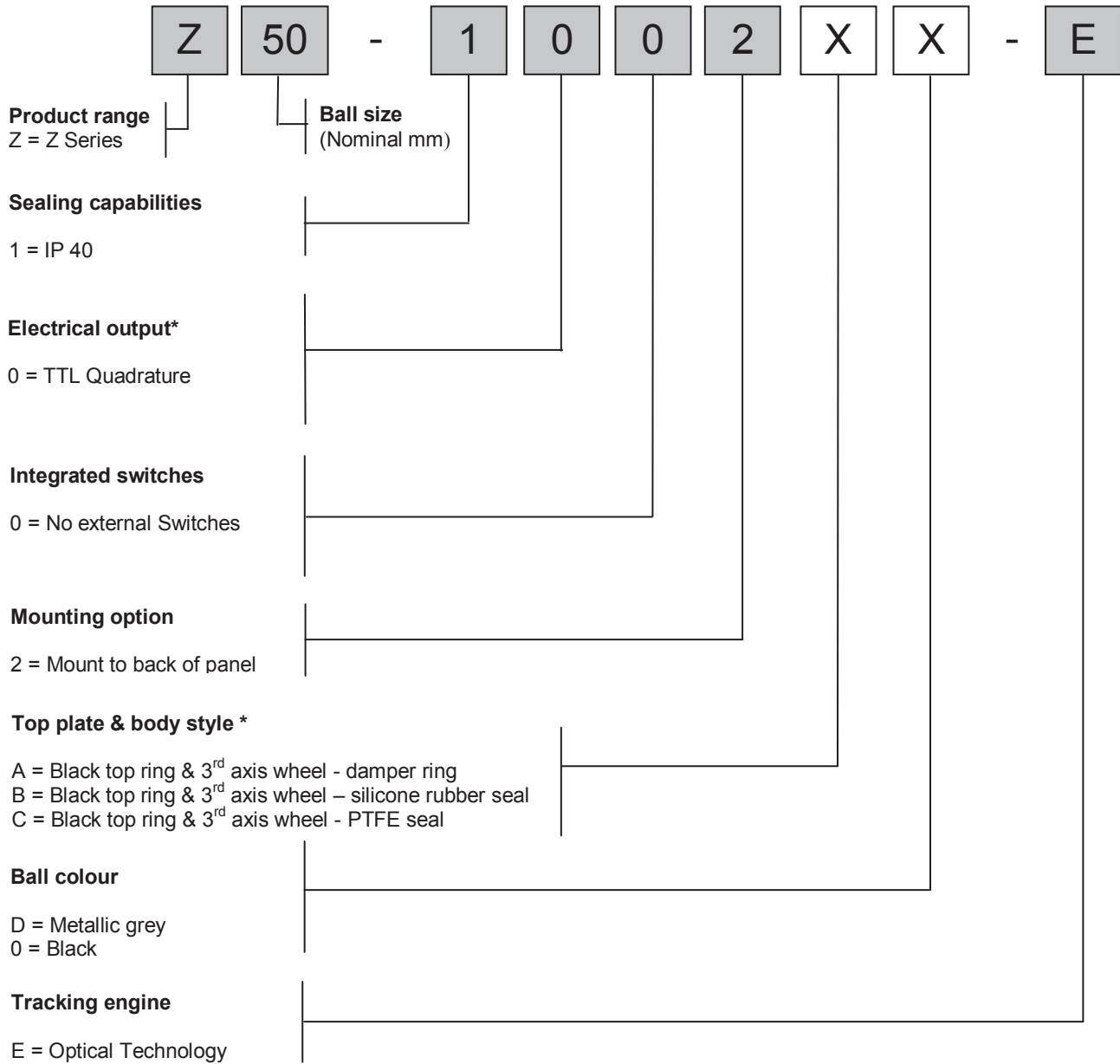

#### 9.1 Ordering Example

**Z50-1002AD-E:** Z50, IP40, TTL quadrature, no switches, mount to back of panel, black top ring & 3<sup>rd</sup> axis wheel - damper ring, metallic grey ball, Optical tracking engine