Z50 Series – Ø50mm IR Optical Trackball, Panel Mount, USB & PS2 Output



1 DESCRIPTION

Utilizing the latest and most advanced optical tracking technology, the Z50 Series optical Trackerball™ is an extremely high specification, contact-less device, ideal for the most demanding of cursor control applications. The device provides both conventional X and Y-axis cursor movement with an additional Z-axis control wheel surrounding the ball. The optical tracking engine combines the benefits of solid state sensing (no moving parts except the ball) with the aesthetics, functionality and performance associated with the Cursor Controls product range. The unit has been designed to be back of panel mounted as part of OEM keyboards and consoles.

2 FEATURES

- Solid state sensing technology – Infra-red optical tracking engine
- Z-axis control wheel for scroll/zoom capability
- Output: USB & PS2 (auto-select)
- Smooth operation in rugged environments
- Various top plate configurations available
- Custom connector options available
- Various ball colours
- Z-axis wheel available with detent scrolling feature

3 APPLICATIONS

- Sound and lighting desks
- Video editing consoles
- Medical systems
- Marine systems
- Custom keyboard applications
- Industrial consoles
- OEM custom solutions available

8 DIMENSION DRAWING

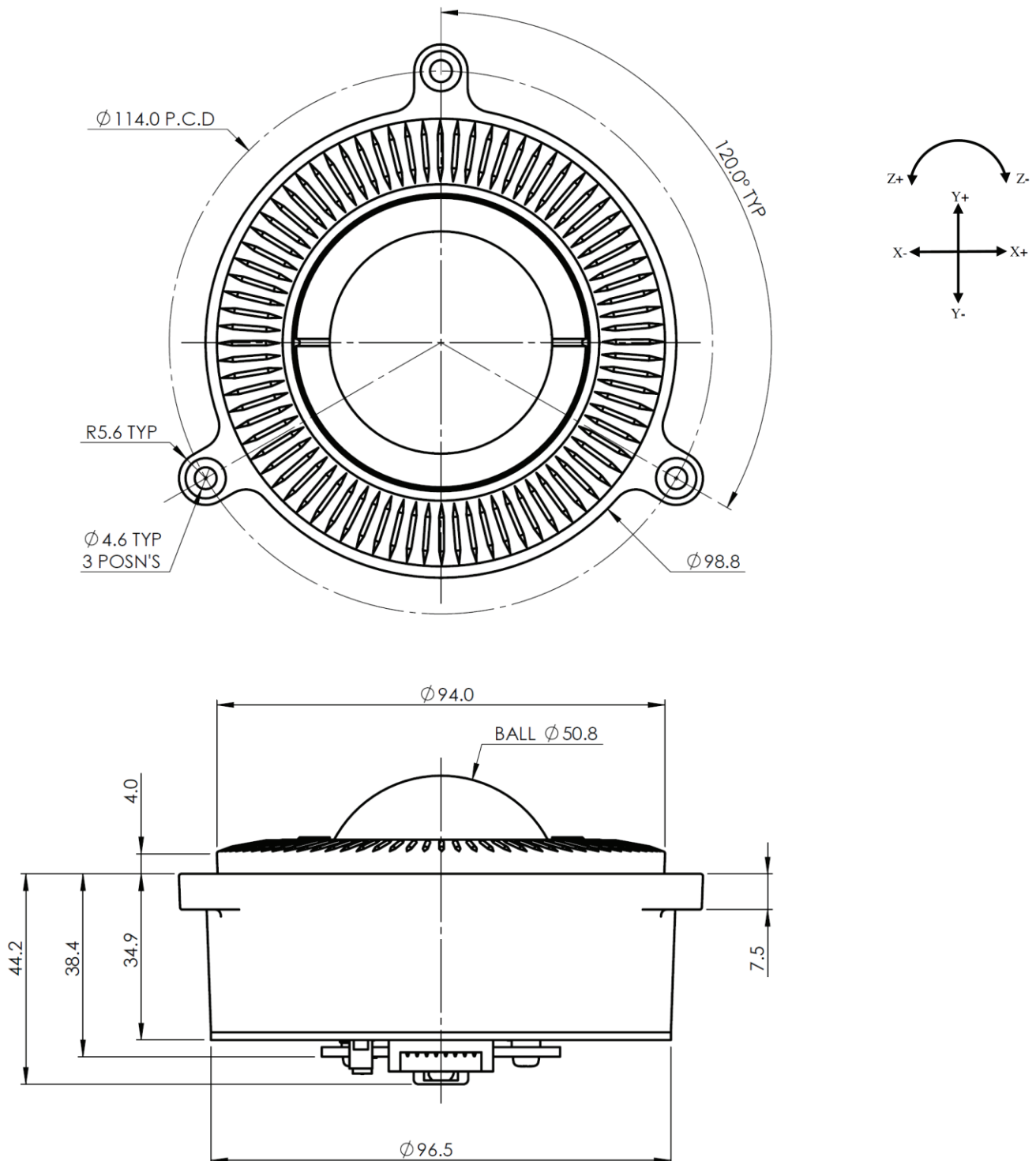

Dimensional drawing specifies factory default orientation.

All dimensions are in mm unless otherwise stated.

Tolerances +/- 0.2mm unless otherwise stated

Please note that an IGES model is available on request. Please contact your local sales office for more information.

9 PRODUCT ORDERING CODE SYSTEM

Please construct your standard product ordering code by selecting the numbers and letters to suit your specification:

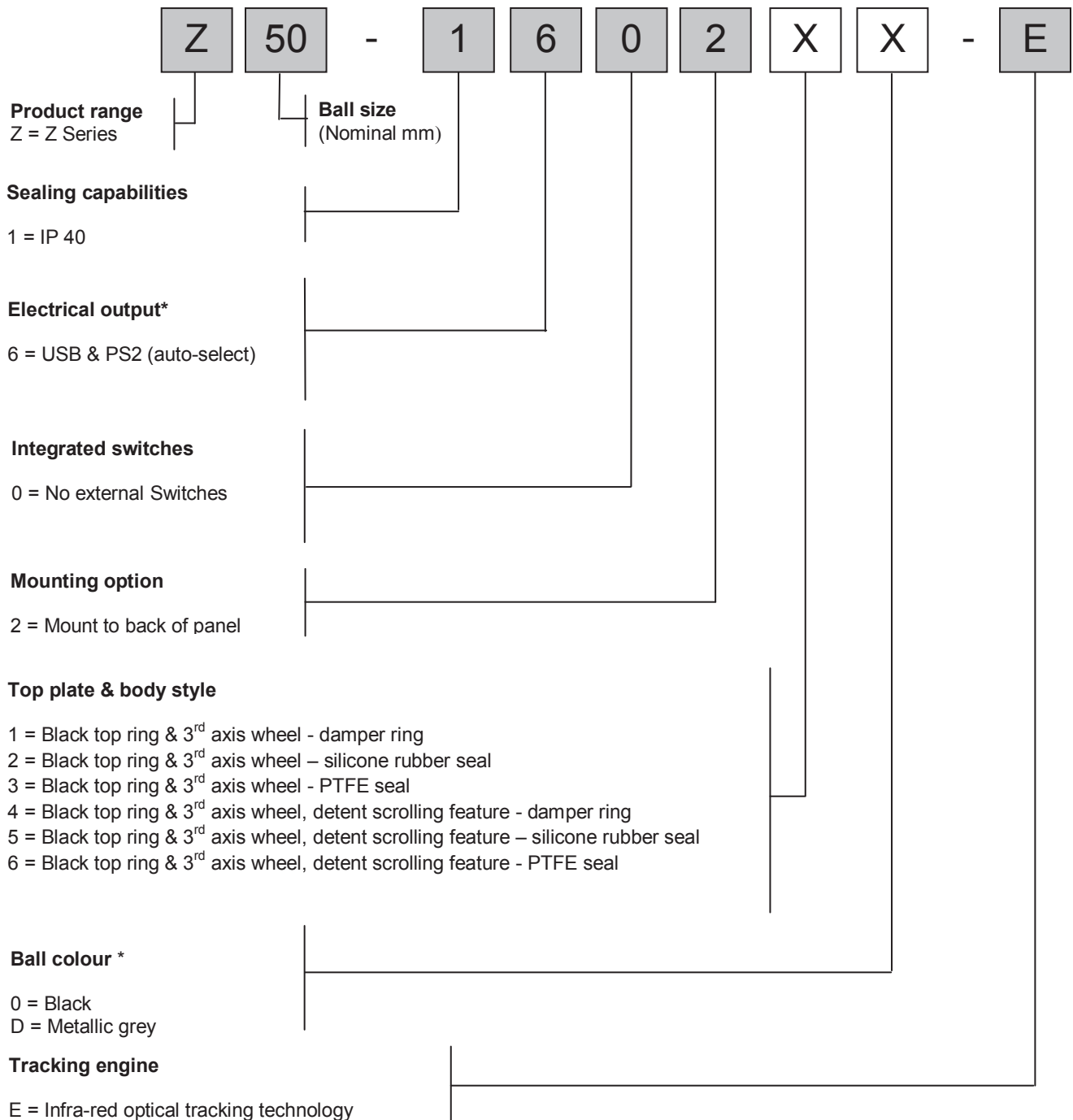

*For further options on ball colours please contact your local sales representative

9.1 Ordering Example

Z50-16021D-E: Z50, IP40, USB/PS2, no switches, mount to back of panel, black top ring & 3rd axis wheel - damper ring, metallic grey ball, IR optical tracking technology.

Z50-160240-E: Z50, IP40, USB/PS2, no switches, mount to back of panel, black top ring & 3rd axis wheel detent scrolling feature, - damper ring, black ball, IR optical tracking technology.