

---

---

**TPM Series: OEM Touchpad Module, 6-inch, USB Output**

---



**Figure 1:** 6" OEM Touchpad Module (shown with standard glass touch surface)

## 1. DESCRIPTION

Using our years of knowledge/experience gained from developing industrial trackball technology, Cursor Controls Ltd have developed a range of advanced touchpad solutions. Cursor Controls touchpads provide smooth and precise cursor control using the latest and most advanced touch sensing technology and are designed for use in the most extreme environments.

The TPM Series OEM touchpad provides both conventional X and Y-axis cursor movement with plug-and-play, multi-finger gesture support for enhanced user interaction. The mutual-capacitance based tracking engine combines the benefits of solid state sensing (no moving parts) with the precision, functionality and performance associated with the Cursor Controls product range. When installed, the design allows for easy cleaning and decontamination, ensuring continued optimum performance and operation under the harshest of conditions. The unit has been designed to be mounted as part of OEM keyboards and consoles.

## 2. FEATURES

- Solid state sensing technology – capacitive touch sensing tracking engine
- Output: USB
- Haptic and audible feedback (function specific)
- Multi-finger gesture support
- 8 capacitive touch feature buttons
- Smooth operation in rugged environments
- Tolerant to moisture, water and liquid contaminants
- Various touch surface overlay options available as standard
- Custom feature button configurations / overlays available

## 3. APPLICATIONS

- Industrial consoles
- Medical systems
- Marine systems
- Sound and lighting desks
- Video editing consoles
- Custom keyboard applications
- OEM custom solutions available

**4. SPECIFICATIONS**

<b>4.1. MECHANICAL</b>		
4.1.1.	Dimensions	143mm x 109mm
4.1.2.	Weight	~100 grams
4.1.3.	Touch Surface Overlay Material	Polyester or Glass (anti-fingerprint & anti-glare) – see Section 10 for ordering details.
4.1.4.	Touch Surface Overlay Colour	Polyester: Metallic grey - Pantone PMS 10393 Glass: Metallic grey - Pantone PMS 10393

<b>4.2. OPERATIONAL</b>		
4.2.1.	Motion Detection Method	Mutual capacitance sensing
4.2.2.	X/Y Position Reporting	Relative
4.2.3.	Sample Rate	Up to 100 samples/sec.
4.2.4.	Touchpad Active Area Size	130mm x 80mm

<b>4.3. ELECTRICAL</b>		
4.3.1.	Protocol	USB
4.3.2.	Supply Voltage	4.40 – 5.25V
4.3.3.	Supply Current	60mA typical - default resolution setting, feedback idle 300mA peak - max resolution setting, feedback effects playing
4.3.4.	Resolution (X, Y)	960 x 720 counts (default setting) – linear tracking mode. See Section 6 for further options.
4.3.5.	Output Connector (CN1)	12-way connector, Molex PicoBlade Series PN: 53261-1271
4.3.6.	Switch Connector (CN2)	6-way connector, Molex PicoBlade Series PN: 53261-0671

<b>4.4. ENVIRONMENTAL</b>		
4.4.1.	Operating Temperature	0° to 70°C
4.4.2.	Operating Humidity	5% to 95% relative humidity
4.4.3.	Storage Temperature	-40° to +85°C
4.4.4.	Vibration	2g, 10-500Hz, 1 octave/min, 10 sweep cycles (IEC 60068-2-6)
4.4.5.	Operating Shock	15g/11ms, ½ sine, 3 shocks in +ve and -ve direction, all 3 axes (IEC 60068-2-27)
4.4.6.	ESD	15kV air-discharge and 8kV contact discharge (IEC 61000-4-2)
4.4.7.	EMC	Radiated immunity - limits according to level 2 of IEC 61000-4-3 Radiated emissions to EN55022 class B

<b>4.5. OPERATING SYSTEM COMPATIBILITY</b>		
4.5.1.	USB	Windows, Linux, Mac OS, and Android
		Fully compliant with USB 2.0 framework (chapter 9) & HID specifications

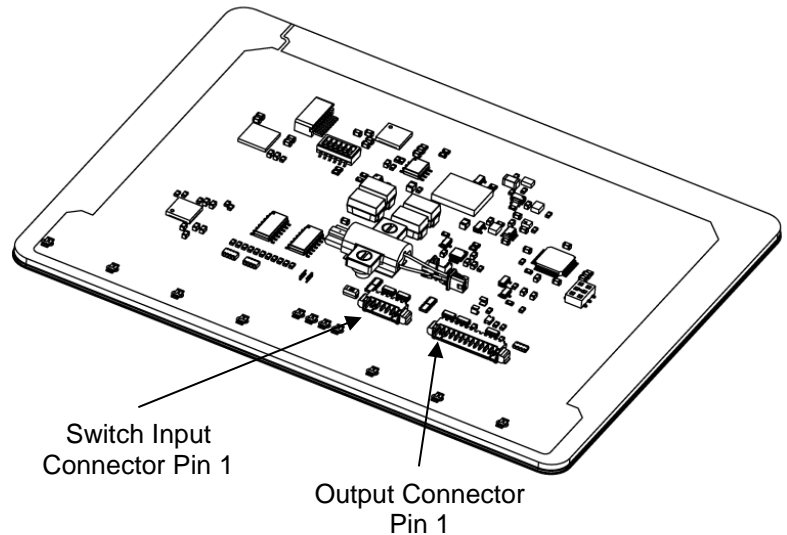
## 5. CONNECTION DETAILS

### 5.1. Output Connector: CN1

<b>Description</b>	12-way, 1.25mm pitch, right-angled connector
<b>Manufacturer</b>	Molex (or equivalent) – Pico Blade Series
<b>Manufacturer Part Number:</b>	53261-1271 (or equivalent)
<b>Mating Connector:</b>	51021-1200 Crimp Housing (or equivalent)

PIN No.	USB
1	NC <sup>1</sup>
2	NC <sup>1</sup>
3	NC <sup>1</sup>
4	NC <sup>1</sup>
5	EARTH <sup>2</sup>
6	NC <sup>1</sup>
7	VBUS (+5V)
8	D -
9	D +
10	GND (0V)
11	NC <sup>1</sup>
12	NC <sup>1</sup>

**Table 1:** Output Connections



**Notes:**

1. Pin to be left unconnected (floating).
2. Earth connection required for ESD management. Please refer to [Section 7](#) for details.

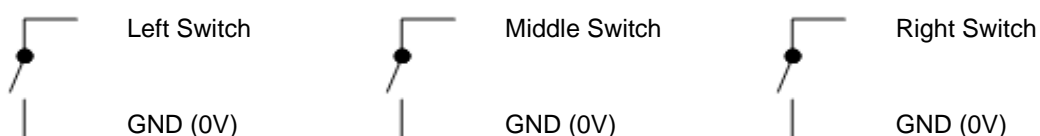
### 5.2. Switch Input Connector: CN2

<b>Description</b>	6-way, 1.25mm pitch, right-angled connector
<b>Manufacturer</b>	Molex (or equivalent) – Pico Blade Series
<b>Manufacturer Part Number:</b>	53261-0671 (or equivalent)
<b>Mating Connector:</b>	51021-0600 Crimp Housing (or equivalent)

PIN No.	FUNCTION
1	Left Switch
2	GND (0V)
3	Middle Switch
4	GND (0V)
5	Right Switch
6	GND (0V)

**Table 2:** Switch Connections

### 5.3. Switch Connection Schematic



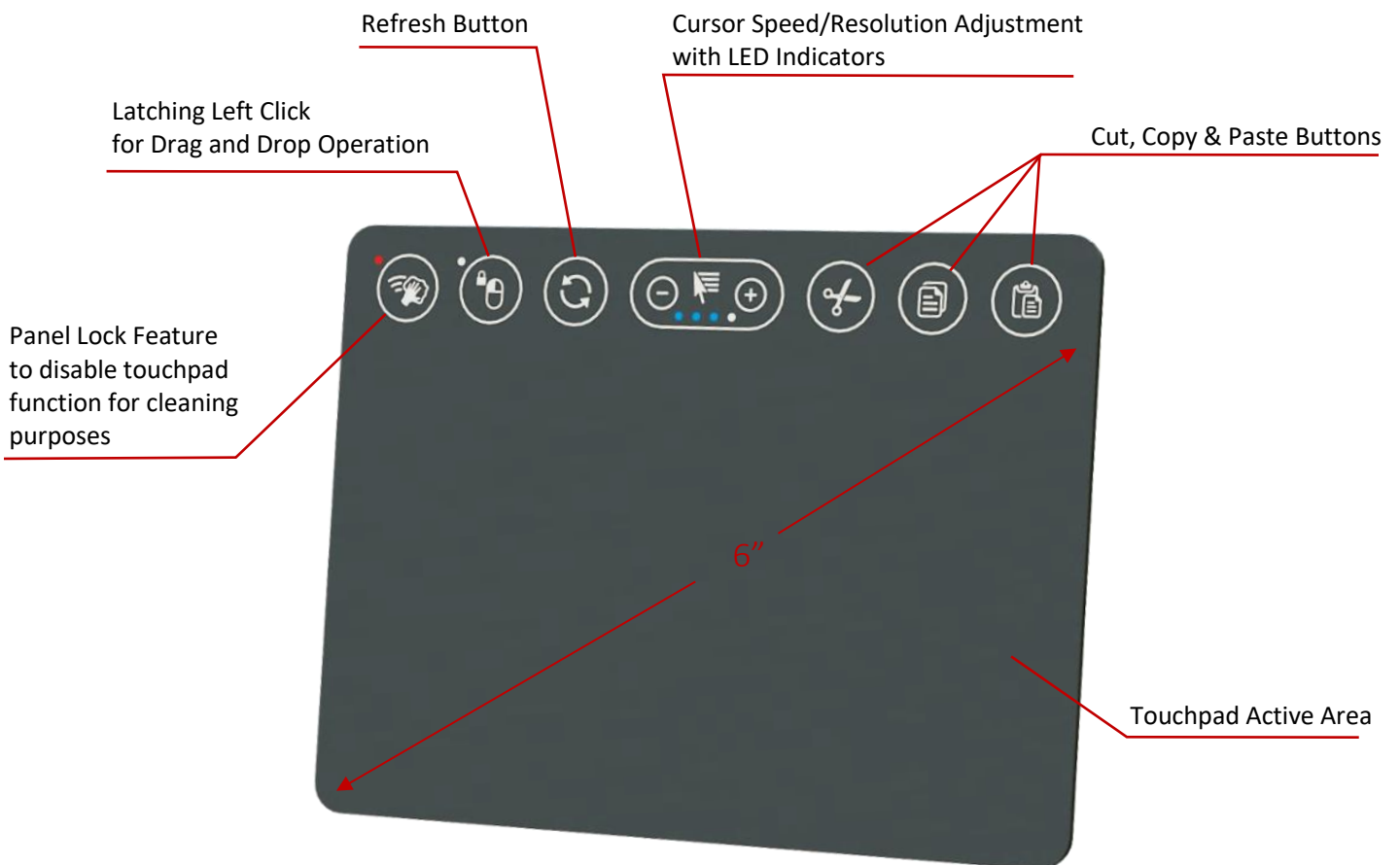
**Figure 2:** Switch connection schematic

## 6. TOUCHPAD FEATURES

### 6.1. Touchpad Features

The TPM Series touchpad module includes the following features / technologies.








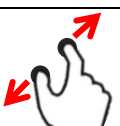
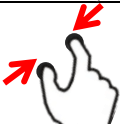


- **Touchpad Technology:** The 6-inch active touchpad area provides both conventional X and Y-axis cursor movement with plug-and-play, multi-finger gesture support for enhanced user interaction (see Section 6.2).
- **Feature Buttons:** 8 x featured buttons are located at the top of the touchpad module. These utilise capacitive touch sensing technology and incorporate frequently used functions such as Cut, Copy & Paste, cursor resolution adjustment etc., as well as a panel lock feature to facilitate cleaning/decontamination of the device.



**Figure 3:** Touchpad Features

### 6.2. Gesture Operations

The touchpad incorporates an in-built gesture recognition engine designed to enhance user experience and increase the overall efficiency of user interaction with a host system. Use of gesture control enables the user to access frequented functions such as button clicks, scrolling and zooming by means of highly intuitive multi-finger operations. See table 3 below for details on the available gesture actions.

GESTURE ACTION		FUNCTION
	<b>Single-Finger Tap</b>	Left mouse button click Double/triple tap supported
	<b>Single-Finger Tap and Drag</b>	Left mouse button click and drag
	<b>Two-Finger Tap</b>	Right mouse button click Double/triple tap supported
	<b>Two-Finger Tap and Drag</b>	Right mouse button click and drag
	<b>Three-Finger Tap</b>	Middle mouse button click Double/triple tap supported
	<b>Two-Finger Vertical Drag</b>	Scroll Up/Down
	<b>Two-Finger Horizontal Drag</b>	Scroll Left/Right <sup>1</sup>
	<b>Two-Finger Splay</b>	Zoom In <sup>1</sup>
	<b>Two-Finger Pinch</b>	Zoom Out <sup>1</sup>
	<b>Three-Finger Swipe Left</b>	Back <sup>1</sup>
	<b>Three-Finger Swipe Right</b>	Forward <sup>1</sup>

**Table 3:** Gesture Operations

Notes:

1. Horizontal scroll and zoom functions are dependent on application support.

### 6.3. Cursor Tracking Mode

The touchpad includes an intuitive **Ballistic Tracking** algorithm to provide increased cursor resolution when tracking fast, whilst retaining the native resolution (960 x 720 counts) for tracking accurately at slow speeds.

The touchpad also includes an **Inertia Tracking** algorithm which applies inertia to the X and Y axis, allowing cursor movement or scroll to continue in the intended direction after the finger(s) is lifted from the touchpad surface, after which the cursor will naturally slow to a stop.

### 6.4. Cursor Speed / Resolution Settings

The touchpad allows the user to increase or decrease the cursor resolution as required across 8 levels, indicated by the LED indicators underneath the + and - buttons. Table 4 below provides details of the resolution provided by each level.

Level	Cursor Resolution	
	X	Y
0	360	240
1	480	360
2	720	540
3 (Default factory setting)	960	720
4	1200	900
5	1440	1080
6	1680	1260
7	1920	1440

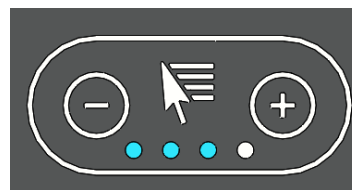


Table 4: Cursor Speed / Resolution Settings

### 6.5. Touchpad Feedback

The touchpad features haptic and audible feedback to provide a perceptible response to user interaction events. Table 5 details the default event mapping for user feedback;

Event	Haptic Feedback	Audio Feedback
Finger Taps (e.g. Left Mouse Click)	No	Yes
Gesture Operations (e.g. Two finger Vertical Drag)	Yes	Yes
Feature Buttons	Yes	Yes
Active Area Edge Detection	Yes	No

Table 5: Haptic / Audible Feedback Configuration

### 6.6. Panel Lock Feature

The panel lock feature allows the touchpad to be locked / disabled for cleaning purposes. This can be achieved by tapping and holding the panel lock button for 3 seconds to toggle ON or OFF. The panel lock LED will remain illuminated whilst the touchpad is locked.

## 7. ELECTROSTATIC DISCHARGE (ESD) PROTECTION

The TPM series touchpad module provides measures to protect against hardware damage due to ESD however, in order to achieve a high-level of immunity to ESD events (up to 15kV), it is necessary to provide adequate earthing methods during system/panel integration, thus providing a low impedance path for charge to dissipate.

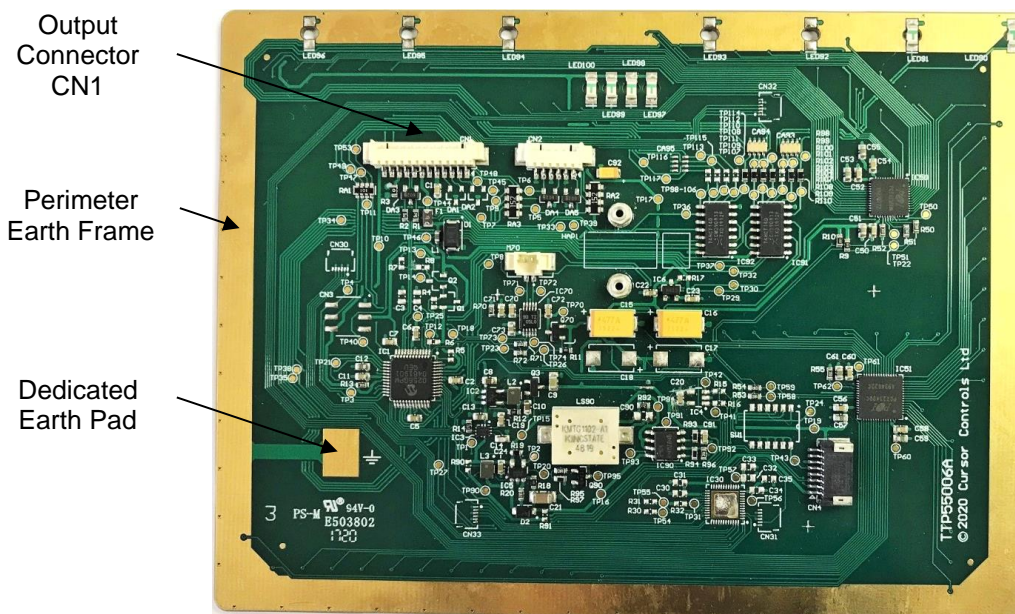
The most likely route for ESD is the creepage path between the user accessible touch surface and the touchpad PCB. The touchpad module provides a conductive perimeter frame on both the top and bottom layers to protect the circuit from ESD strikes (see figure 5). It is necessary to provide a suitable connection between the perimeter frame and earth or chassis-ground.

Possible earthing methods include;

1. Housing the touchpad module within an earthed conductive interface panel (e.g. metal keyboard frame), ensuring that there is sufficient contact between the perimeter frame of the touchpad module and the interface panel.
2. Attaching an earth connection to Pin 5 (EARTH) of the output connector CN1 – this pin is internally connected to the perimeter frames. A convenient method for providing an earth connection to this pin is to use the USB or PS/2 cable shield or drain wire.
3. Attach an earth wire directly to the perimeter frame. Using the dedicated earth pad shown in the image below to do this is recommended.

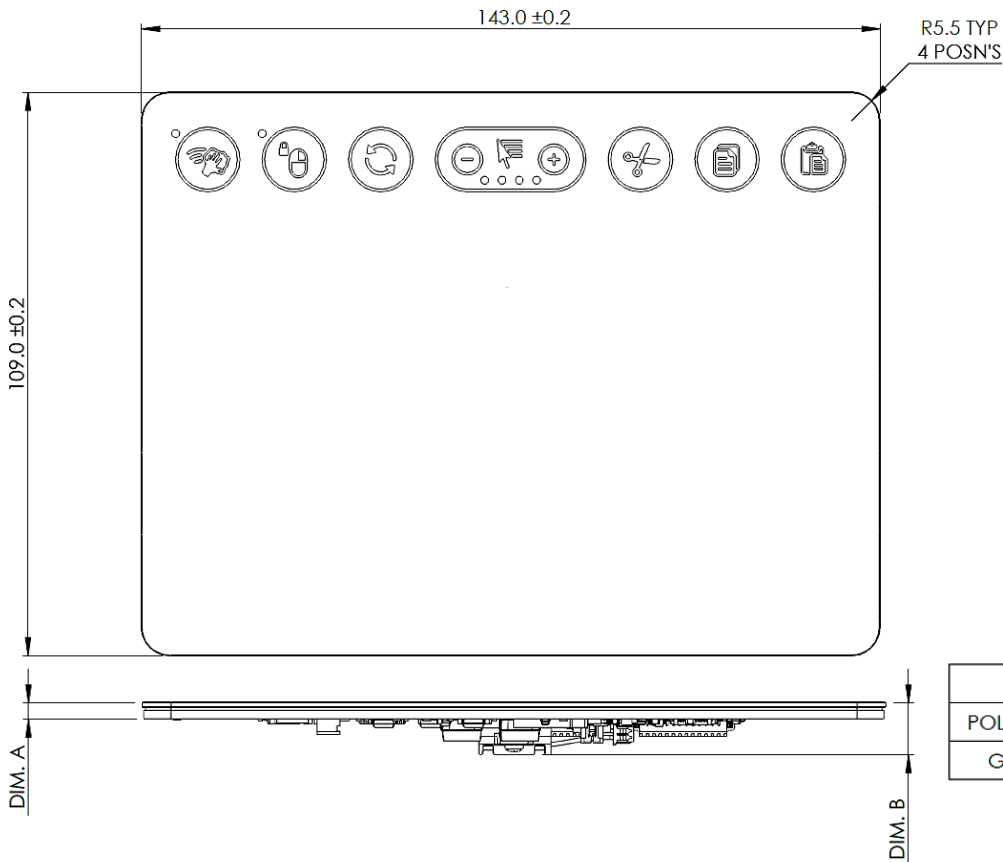
In addition, it is important that customer interface panels made up of conductive or non-conductive materials are suitably earthed as follows:

- Conductive interface panel: In this case, there is no requirement for an earth connection to the touchpad device. It is, however, essential that the conductive interface panel is earthed and in sufficient contact with the perimeter frame of the touchpad in order to provide adequate ESD protection as detailed in Method 1 above.
- Non-conductive interface panel: An earth connection must be attached to the touchpad module. Methods 2 & 3 recommended above can be used to achieve this.

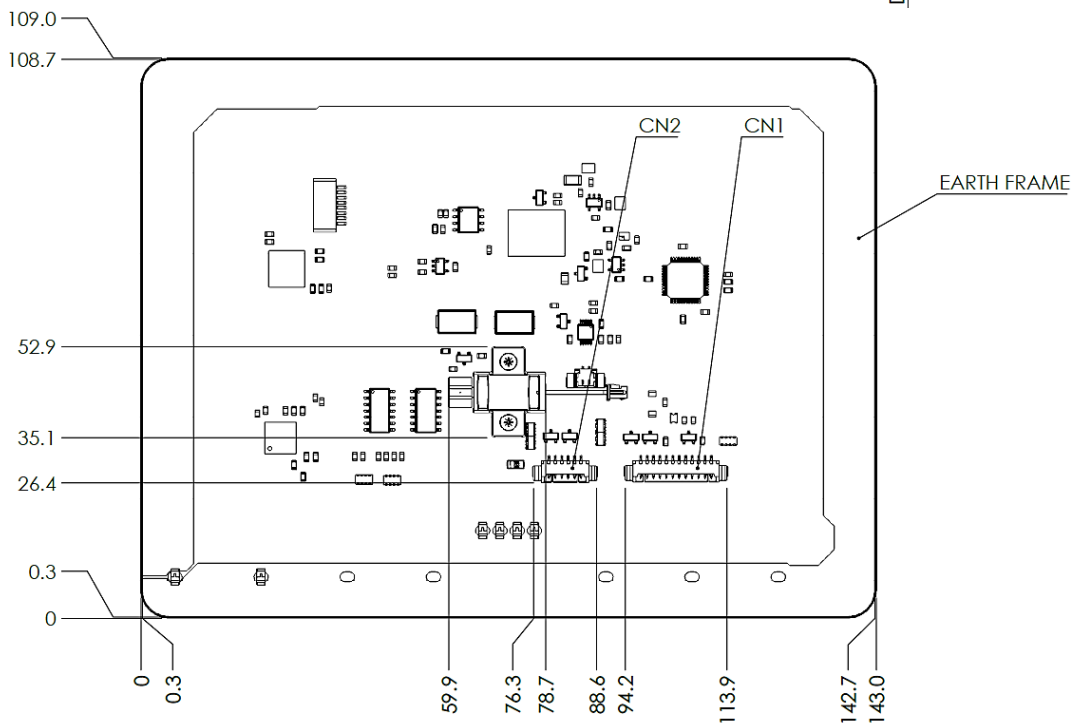


**Figure 5:** Perimeter Earth Frame on TPM Series PCB.

8. TOUCHPAD DIMENSION DRAWING



VARIANT	DIM. A	DIM. B
POLYESTER OVERLAY	2.6	9.5
GLASS OVERLAY	3.2	10.1



Dimensional drawing specifies factory default orientation.

All dimensions are in mm unless otherwise stated.

Tolerances +/- 0.2mm unless otherwise stated

Please note that an IGES model is available on request. Please contact your local sales office for more information.



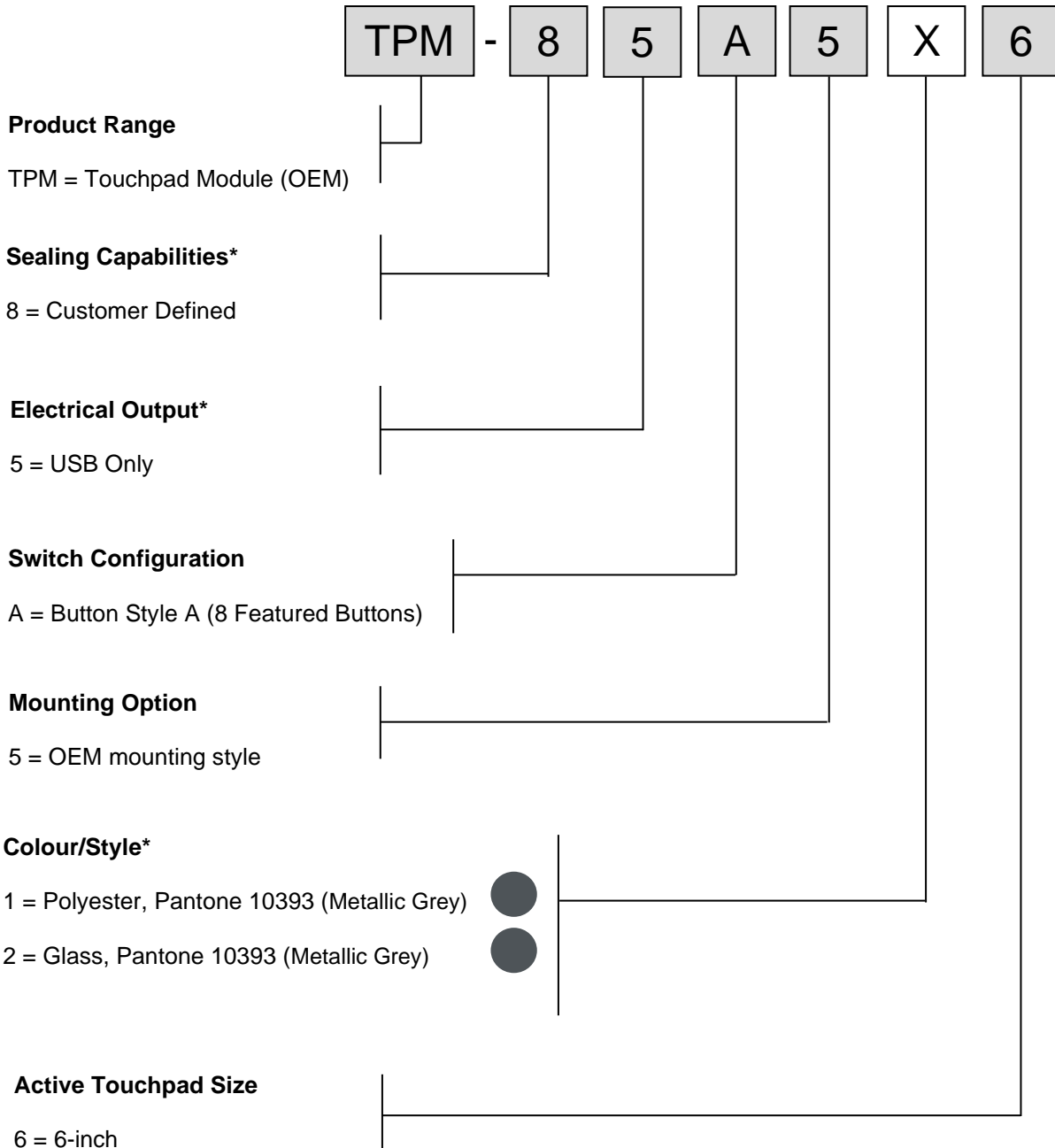
## 9. MOUNTING RECOMMENDATIONS

The TPM series touchpad module can be mounted into panels and consoles using various methods.

For details of typical mounting methods applicable to this module, please refer to Cursor Controls Ltd Application Note AN0060. Please contact your local sales office for further details.

### 10. PRODUCT ORDERING CODE SYSTEM

Please construct your standard product ordering code by selecting the numbers and letters to suit your specification:



*\*For further options please contact your local sales representative.*

#### 10.1. Ordering Example

**TPM-85A516:** Touchpad, Customer defined sealing, USB Interface, 8 x feature buttons, OEM style, Pantone 10393 (Metallic Grey) polyester overlay, 6-inch.

## 11. DOCUMENT HISTORY

Issue	Date	Author	Remarks
A	03/07/19	O. O	<ul style="list-style-type: none"><li>Document released</li></ul>
B	20/07/20	O.O	<ul style="list-style-type: none"><li>Polyester overlay thickness increased</li><li>Overlay colours revised</li><li>EMC radiated immunity specification revised</li><li>DIP Switch function for feedback configuration removed</li></ul>
C	10/08/21	O.O	<ul style="list-style-type: none"><li>Module weight updated</li><li>Dimension drawing updated</li><li>Product illustration updated</li></ul>

All information contained herein should be regarded as confidential and is supplied subject to Cursor Controls Ltd Terms and Conditions – a copy of which is available on request or can be found at [www.cursorcontrols.com/terms-conditions](http://www.cursorcontrols.com/terms-conditions)

Whilst the information provided herein is to the best of our knowledge true and accurate, it should be used for guidance only and may be subject to change. You are therefore advised to ensure all information provided herein is current and up to date and suitable for your application. Use of Cursor Controls Ltd products in life support/critical systems is only permitted with prior written consent of the Company.